

40V Lithium 16" Mower  
Instruction Manual

LB4010001

**LawnMaster**<sup>®</sup>

LITHIUM

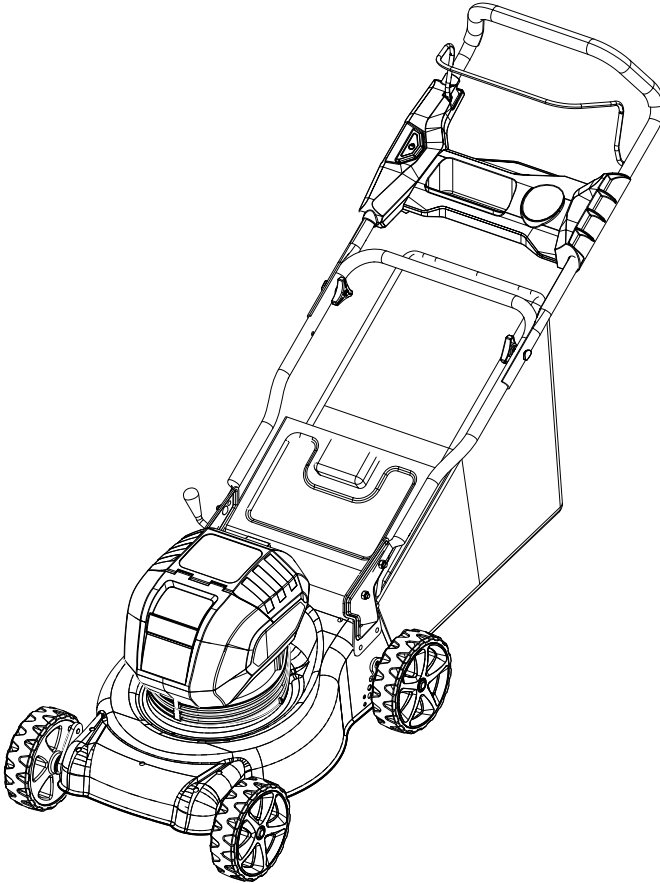

**Important!**

It is essential that you read the instructions in this manual before operating this machine.

All notes and images are subject to technical modification.

Distributed by Steelfort Engineering Ltd

# READ FIRST BEFORE USE!

## LawnMaster Lithium Battery Instructions

1. Battery must be fully charged before initial use.
2. Never let the battery discharge below two bars on the battery indicator light- discharging below two bars may cause damage to the battery.
3. Do not continue use if machine stops - fully recharge battery first if below two bar indicator. If above the two bar minimum assess the tool for potential obstructions.
4. We recommend to fully recharge the battery immediately after every use. Allow the battery to cool for at least 15 minutes before recharging.
5. Do not store for a long period without fully recharging battery.
6. Check battery temperature . If above 38°C let battery rest and cool.

Lithium batteries do not need to be fully discharged before recharging.

---

## INDEX

INTRODUCTION	4
SAFETY RULES AND PRECAUTIONS	4
CHILD SAFETY	7
BATTERY AND CHARGER SAFETY RULES	7
SLOPE GAUGE	8
WARNING SYMBOLS	10
PRODUCT DESCRIPTION	11
DETAILED DESCRIPTION OF THE PRODUCT	11
TECHNICAL DATA	13
ASSEMBLY	13
UNPACKING	13
UNFOLDING AND ADJUSTING HANDLE ASSEMBLY (1)	14
INSTALLING THE MULCHING PLUG (FOR MULCHING OPERATION) (2)	15
INSTALLING THE GRASS CATCHER (FOR REAR BAGGING OPERATION) (3)	15
TO INSTALL BATTERY (4)	16
USING THE PRODUCT	17
STARTING/STOPPING THE MOWER (1)	17
SETTING BLADE HEIGHT (2)	17
MOWING TIPS	18
MULCHING TIPS	18
EMPTYING THE GRASS CATCHER BAG (3)	19
BATTERY AND CHARGER	19
CARE AND MAINTENANCE	20
REPLACING THE CUTTING BLADE	20
REMOVE BATTERY	20
CLEANING THE MOWER	21
SERVICE AND ADJUSTMENTS	21
TRANSPORTING LITHIUM BATTERIES	22
RECYCLING AND DISPOSING	23
GUARANTEE	23

## INTRODUCTION

Thank you for choosing this LawnMaster product. We are sure you shall appreciate the quality and performance of this machine, which will facilitate your task for a long period of time.

Remember that you can contact our Technical Support for any queries regarding assembly or maintenance, as well as for the resolution to any problems that may arise, and for the purchase of spare parts and/or accessories.



### WARNING

Please read these Operating Instructions carefully as well as the safety precautions before using your device. Failure to do so could result in an electric fault, fire hazard and/or in personal injury. The manufacturer will not take responsibility for accidents or injuries caused to the user, third parties or objects as a result for not following the instructions in the user manual.



### WARNING

This machine must only be used to mow lawns. Do not attempt to use this machine for other purposes for which the machine is not intended for, such as to clear land, for leaf or debris collection, to trim hedges, pruning bushes or for cutting vegetation other than grass. Do not use this machine as a crushing machine. Using the lawnmower for other purposes the machine is not intended for may lead to dangerous situations.

This machine is not intended for professional use.

Keep this user manual safe for future reference. Should you sell this machine in the future, please remember to hand it to the new owner.

---

## WARNING SYMBOLS

### KNOW YOUR LAWN MOWER

Read this manual carefully, observing the recommended safety instructions before, during and after using your lawn mower. Following these simple instructions will also maintain your lawn mower in good working order. Familiarize yourself with the controls on your mower before attempting to operate it, but above all, be sure you know how to stop your mower in an emergency.

## 1. SYMBOLS MARKED ON THE PRODUCT



Read this instruction book carefully before using the lawn mower and keep it in a safe place for future reference



Keep bystanders away.



Beware of sharp blades. Blades continue to rotate after the motor is switched off



Switch off isolator key before adjusting, cleaning and before leaving the product unattended for any period.



The charger is intended for indoor use only.



Wear hearing and eye protection



Do not expose to rain or damp conditions.



Do not operate on inclines greater than 15°  
Mow across the face of slopes, never up and down.



Wait until all machine components have completely stopped before touching them.



CE Marking

The product meets demands and regulations set by the European Community.



**CAUTION!** Unusable power tools do not belong in domestic waste. They must be taken to a communal collecting point for environmentally friendly disposal in accordance with local regulations

### Disposing of the packaging:

The packaging is made of cardboard please recycle.

### Battery packs/batteries:



**Li-Ion**

Do not dispose of batteries into household waste, water or fire. Battery packs/batteries must be collected or recycled.

**Only for EC countries:**

Defective or dead batteries must be recycled according to the directive 2006/66/EC

Li-Ion



Noise level marking

Your tool noise is not more than 94dB.



### SAFETY ALERT SYMBOL:

Indicates caution or warning may be used in conjunction with other symbols or pictures.

## 2. GENERAL SAFETY RULES

The purpose of the safety rules is to attract your attention to possible dangers. The safety symbols and the explanations with them, require your careful attention and understanding. The safety warnings do not by themselves eliminate any danger. The instruction or warnings they give are not substitutes for proper accident prevention measures.



**WARNING:** Failure to obey a safety warning can result in serious injury to yourself or to others. Always follow the safety precautions to reduce the risk of fire, electric shock and personal injury. Save owners manual and review frequently for continuing safe operation and instructing others who may use this tool.



**WARNING:** This machine produces an electromagnetic field during operation. This field may, under some circumstances, interfere with active or passive medical implants. To reduce the risk of serious or fatal injury, we recommend persons with medical implants consult their physician and the medical implant manufacturer before operating this machine.

**!** **WARNING:** The operation of any tool can result in foreign objects being thrown into your eyes, which can result in eyes severely damaged. Before beginning power tool operation, always wear safety goggles or safety glasses with side shields and a full face shield when needed. We recommend Wide Vision Safety Mask for use over eyeglasses or standard safety glasses with side shield.

**IMPORTANT**  
**READ CAREFULLY BEFORE USE.**  
**KEEP FOR FUTURE REFERENCE.**

- 1) Read the instructions carefully. Be familiar with the controls and the proper use of the equipment;
  - 2) Never allow children or people unfamiliar with these instructions to use the lawnmower. Local regulations can restrict the age of the operator
  - 3) Never mow while people, especially children, or pets are nearby;
  - 4) Keep in mind that the operator or user is responsible for accidents or hazards occurring to other people or their property.
  - 5) While mowing, always wear substantial footwear and long trousers. Do not operate the equipment when barefoot or wearing open sandals; Avoid wearing clothing that is loose fitting or that has hanging cords or ties.
  - 6) Thoroughly inspect the area where the equipment is to be used and remove all objects which can be thrown by the machine.
  - 7) Before using, always visually inspect to see that the blades, blade bolts and cutter assembly are not worn or damaged. Replace worn or damaged blades and bolts in sets to preserve balance. Replace damaged or unreadable labels.
  - 9) mow only in daylight or in good artificial light;
  - 10) avoid operating the equipment in wet grass, where feasible;
  - 11) Always be sure of your footing on slopes;
  - 12) Walk, never run;
  - 13) For wheeled rotary machines; mow across the face of slopes, never up and down;
  - 14) exercise extreme caution when changing direction on slopes;
  - 15) Do not mow excessively steep slopes;
  - 16) Use extreme caution when reversing or pulling the lawnmower towards you;
  - 17) Stop the blades if the lawn mower has to be tilted for transportation when crossing surfaces other than grass, and when transporting the lawn mower to and from the area to be mowed;
  - 18) Never operate the lawnmower with defective guards, or without safety devices, for example deflectors and/or grass catchers, in place;
  - 19) Start or switch on the motor carefully according to instructions and with feet well away from the blades;
  - 20) Do not tilt the lawnmower when starting switching on the motor, except if the lawnmower has to be tilted for starting. In this case, do not tilt it more than absolutely necessary and lift only the part which is away from the operator;
  - 21) Do not start the motor when standing in front of the discharge chute;
  - 22) Do not put hands or feet near or under rotating parts. Keep clear of the discharge opening at all times
  - 23) Never pick up or carry a lawnmower while the motor is running;
  - 24) Stop the motor and switch off isolator key. Make sure that all moving parts have come to a complete stop.
    - whenever you leave the machine;
    - before clearing blockages or unclogging chute;
    - before checking, cleaning or working on the lawnmower;
    - after striking a foreign object. Inspect the lawnmower for damage and make repairs before restarting and operating the lawnmower;
- If lawnmower starts to vibrate abnormally (check immediately);

- inspect for damage;
  - replace or repair any damage parts.
  - check for and tighten any loose parts.
- 25) Stop the mower:
- whenever you leave the lawnmower;
- 26) keep all nuts, bolts and screws tight to be sure the equipment is in safe working condition;
- 27) check the grass catcher frequently for wear or deterioration;
- 28) Replace worn or damaged parts for safety;
- 29) Children are not allowed to use the machine.
- 30) This appliance is not intended for use by persons with reduced physical, sensory or mental capabilities, or lack of experience and knowledge, unless they have been given supervision or instruction concerning use of the appliance by a person responsible for their safety.
- 31) Be careful during adjustment of the machine to prevent entrapment of the fingers between moving blades and fixed parts of the machine.
- 32) Always allow the machine to cool before storing.
- 33) After use and before storage, remove the battery from the machine and check for damage.
- 34) When servicing the blades be aware that, even though the power source is switched off, the blades can still be moved.
- 35) Replace worn or damaged parts for safety; Use only genuine replacement parts and accessories.
- 36) Be careful during adjustment of the appliance to prevent entrapment of the fingers between moving blades and fixed parts of appliance.
- 37) Recharge only with the charger specified by the manufacture .Using a charge with an incompatible battery pack may create a risk of fire.
- 38) Use power tools only with specifically designated battery packs .Use of any other battery packs may create a risk of injury and fire.
- 39) When battery pack is not in use ,keep it away from other metal objects like ,paper clips ,coin, keys, nails, screws ,or other small metal objects, that can make a connection from one terminal to another. Shorting the battery terminals together may cause burns or a fire.
- 40) Under abusive conditions, liquid may be ejected from the battery:
- If contact accidentally occurs, flush with water.
  - If liquid contacts eyes additionally seek medical help. Liquid ejected from the battery may cause irritation or burns.
- 41) When device is not in use, keep it away from other metal objects like paper clips, coins, keys, nails, screws, or other small metal objects that can make a connection from one terminal to another. Shorting the battery terminals together may cause burns or a fire.
- 42) Under abusive conditions, liquid may be ejected from the battery, avoid contact if it occurs, flush with water. If liquid contacts eyes, additionally seek medical help. Liquid ejected from the battery may cause skin irritation or burns.
- 43) this appliance can be used by children aged from 8 years and above and persons with reduced physical, sensory or mental capabilities or lack of experience and knowledge if they have been given supervision or instruction concerning use of the appliance in a safe way and understand.
- 44) children shall not play with the appliance.
- 45) cleaning and user maintenance shall not be made by children without supervision.

### **Safety Advice for Rechargeable Battery and Charger**

Use only the battery provided with the lawn mower and the provided charger.

Protect battery and battery charger from humidity.

Do not operate the battery charger outdoors.

---



When it is not in use or before cleaning and servicing, disconnect the battery charger from the power supply. Take special care of the battery.  
 Avoid dropping it onto any hard surface or any other form of mechanical stress.  
 Keep the battery away from extreme heat and cold.

Do not open or attempt to repair the battery or the battery charger. If any parts are defective, have them repaired by a qualified technician.

Only charge the battery at an ambient temperature between 0°C and +40°C.

A charged battery can be used to power the machine under ambient temperature conditions between 20°C and +50°C.

When not in use, store the battery in a dry place between 10°C and 30°C.

**The battery should be recharged when it fails to produce sufficient power on jobs which were easily done previously. DO NOT CONTINUE** using product with its battery in a depleted condition.

**The battery is not fully charged at the factory.** Before attempting to use the battery it must be fully charged first.



**WARNING:**

Never shortcircuit the battery or expose it to moisture. Do not store it together with any metal parts which could shortcircuit the contacts. The battery could overheat, start burning or explode.

If any person comes into contact with acid or similar internal fluids or substances contained in the battery, wash off these substances immediately with plenty of water. If these substances make contact with the eyes, rinse with plenty of water and visit a doctor immediately.



**WARNING:** Do not open the battery pack to get the battery out by yourself.

Do not place the rechargeable battery into fire or water. It can explode. The Rechargeable Battery should not be discarded to domestic refuse, regardless of whether used or unused. You should return it to a local battery collection point in accordance with Battery Regulations.

## CHILD SAFETY

Tragic accidents can occur if the operator is not aware of the presence of children.

- Keep children out of the mowing area and under the watchful care of a responsible adult.
- Do not allow children under the age of 14 to operate this mower. Children who are 14 years of age and older must read and understand the operating instructions and safety rules in this manual, and must be trained and supervised by a parent.
- Stay alert, and turn the mower off if a child or any other person enters the mowing area.
- Look behind and down for small children before and while moving backwards.
- Use extreme care when approaching blind corners, doorways, shrubs, trees, or other objects that may obscure your view of a child who may run into the path of the mower.

## PRODUCT DESCRIPTION

### DETAILED DESCRIPTION OF THE PRODUCT

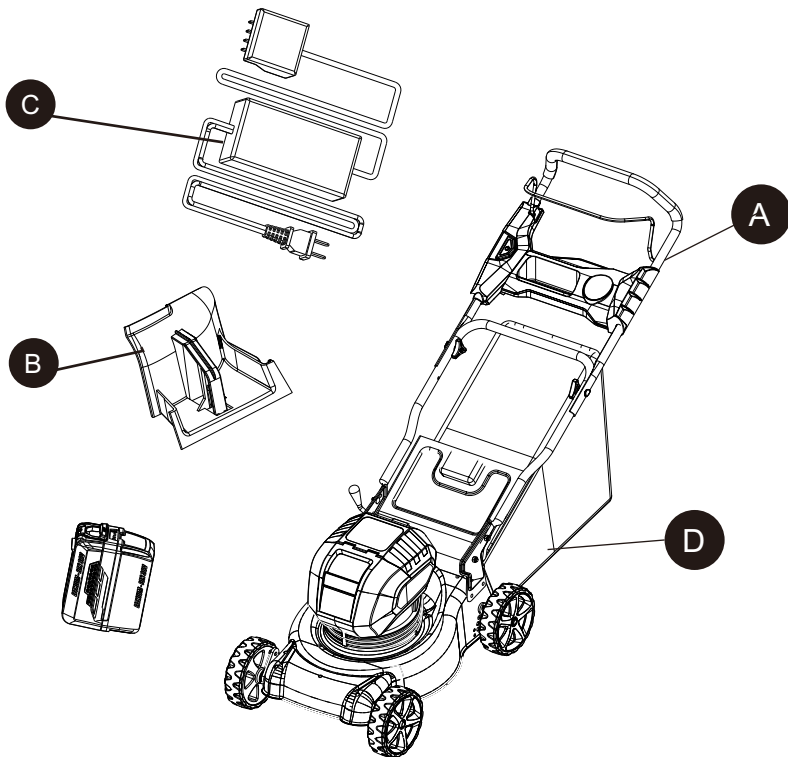

PART	DESCRIPTION	QUANTITY
A	Lawn mower	1
B	Mulching plug	1
C	Charger	1
D	Grass catcher bag	1
E	Battery 40v 4.0Ah	1

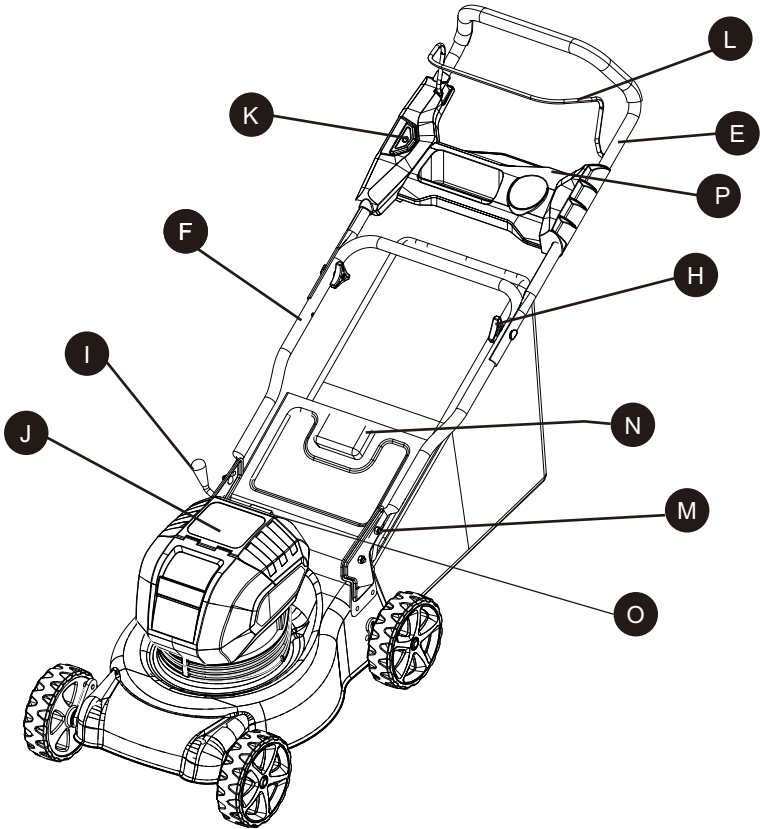

PART	DESCRIPTION	QUANTITY
E	Upper handle	1
F	Lower handle	1
H	Cam locks	2
I	Height adjustment lever	1
J	Battery door	1
K	Start button	1
L	Bail switch	1
M	Lower handle locks	1
N	Rear discharge cover	1
O	Battery release button	1
P	Cup holder	1

## TECHNICAL DATA

CORDLESS LAWNMOWER	
Model	LB4010001
Battery type	40 V DC Lithium-ion
Charge time	2 hours (4.0Ah battery)
No-load speed	3000-3500 rpm
Cutting width	400 mm
Container capacity	50 L
Height adjustments	Adjustable 25-75mm
Functions	2-in-1: Mulch or rear bag
Unit weight (without battery)	20 kg

BATTERY AND CHARGER	
Battery Pack	LB40B
Charger	LB40BCKT

## ASSEMBLY

### UNPACKING

Before beginning assembly of product, make sure all parts are present. Compare parts with package contents list and hardware contents list. If any part is missing or damaged, do not attempt to assemble the product.

- Carefully remove the product and any accessories from the box. Make sure that all items listed in the packing list are included.
- Inspect the product carefully to make sure no breakage or damage occurred during shipping.
- Do not discard the packing material until you have carefully inspected and satisfactorily operated the product.
- If any parts are damaged or missing, please call dealer for assistance.

Estimated Assembly Time: 5 minutes



#### WARNING

- If any parts are damaged or missing do not operate this product until the parts are replaced. Using a product with damaged or missing parts could result in serious personal injury.
- Do not attempt to modify this product or create accessories not recommended for use with this product. Any such alteration or modification is misuse and could result in a hazardous condition leading to possible serious personal injury.

- Do not insert battery until assembly is complete and you are ready to mow. Failure to comply could result in accidental starting and possible serious personal injury.
- To prevent accidental starting that could cause serious personal injury, always remove the battery from the product when assembling parts.
- Never operate the mower without the proper safety devices in place and working. Never operate the mower with damaged safety devices. Operation of this product with damaged or missing parts could result in serious personal injury.

### INSTALL CUP HOLDER (1)

#### 1. Install cup holder :

- Open attachment bag find 4 PCS M4x15 screw and find the cup holder (P) in packing box.
- Install cup holder (P) to upper handle assembly and lock screw.

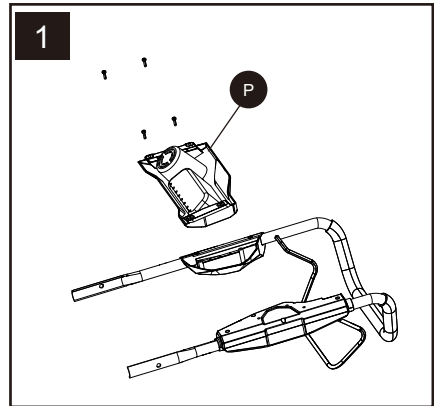

### UNFOLDING AND ADJUSTING HANDLE ASSEMBLY (2)

#### a. To raise handle assembly:

- Pull up and back on the lower handle (F) until it is aligned with the hole position of the arm support and the mower housing.
- To secure the lower handle (F) in place, lock the lower screw (M).
- Open the upper cam locks (H).
- Pull up and back on the upper handle to raise it into operating position.
- To secure the upper handle in place, close the upper cam locks (H).

**NOTE:** If the upper handle is loose or separated from the lower handle, tighten the knobs on the upper handle locks by turning them clockwise.

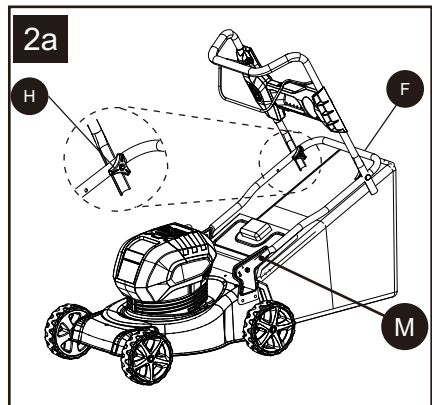

b. To lower the handle assembly:

- Open the upper cam locks (H).

NOTE: If the handle lock is difficult to open, loosen the knobs on the upper handle locks by turning them counterclockwise.

- Lower the upper handle.
- Unfix the lower screw (M).
- Fold the handle to the front of the unit.
- Avoid pinching or trapping any cables.

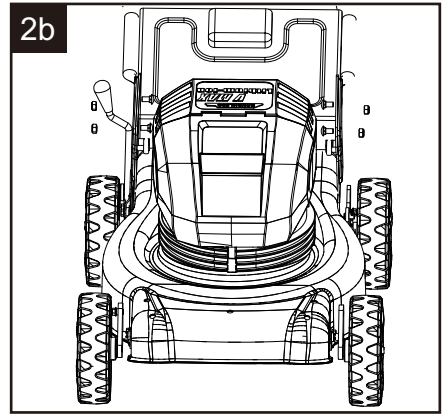

### INSTALLING THE MULCHING PLUG (FOR MULCHING OPERATION) (3)

NOTE: When using the mulching plug (B), do not install the grass catcher.

- Remove battery.
- Lift and hold the rear discharge door (N).
- Grasp the mulching plug (B) by its handle and insert it at a slight angle.
- Push the mulching plug (B) securely into place.
- Lower the rear discharge door.
- Reinstall battery when you are ready to mow.

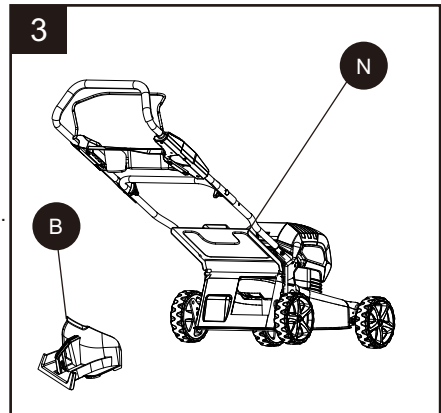

## INSTALLING THE GRASS CATCHER (FOR REAR BAGGING OPERATION) (4)

NOTE: When using the grass catcher (D), do not install the mulching plug.

- Remove battery.
- Lift the rear discharge door (N).
- Lift the grass catcher (D) by its handle and place under the rear discharge door (N) so that the hooks on the grass catcher are seated onto the slots on the mower housing.
- Release the rear discharge door (N).
- Reinstall battery when you are ready to mow.

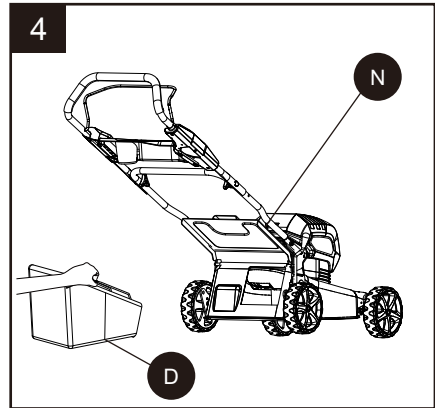

## TO INSTALL BATTERY (5)



### WARNING

Always remove battery from your tool when you are assembling parts, making adjustments, cleaning, or when not in use. Removing battery will prevent accidental starting that could cause serious personal injury.

- Raise the battery cover (J).
- Place the battery in the mower.
- Align raised ribs on battery with grooves in the mower's battery port.
- Push down into battery compartment until the battery clicks into place.
- Lower the battery cover.

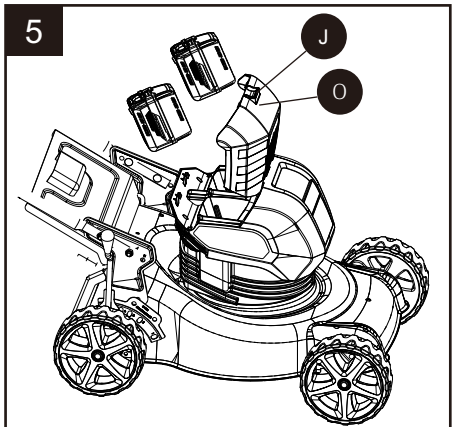

### WARNING

Make sure the latch on top of the battery with battery release button snaps in place and the battery is fully seated and secure in the mower's battery port before beginning operation. Failure to securely seat the battery could cause the battery to fall out, resulting in serious personal injury.

To remove battery

- Press the battery release button (O) on the mower. This will cause the battery to raise out of the tool slightly.
- Raise the battery cover.
- Remove battery from the mower.

## USING THE PRODUCT

### STARTING/STOPPING THE MOWER (1)

- Raise the battery cover.
- Install battery.
- Lower the battery cover.
- Press and hold the start button (K). Pull the bail switch (L) toward the handle and release the button to start the mower.
- To stop the mower, release the bail.

NOTE: Power save feature automatically adjusts the cutting speed of the blades to match the application to give the best possible cut while maximizing run time and battery life.

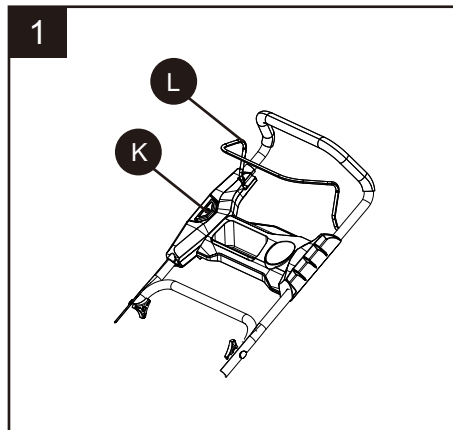

### SETTING BLADE HEIGHT (2)

When shipped, the wheels on the mower are set to a low-cutting position. Before using the mower for the first time, raise the cutting position to the height best suited for your lawn.

To adjust the blade height:

- To raise the blade height, grasp the height adjustment lever and move it toward the front of the mower.
- To lower the blade height, grasp the height adjustment lever and move it toward the back of the mower.

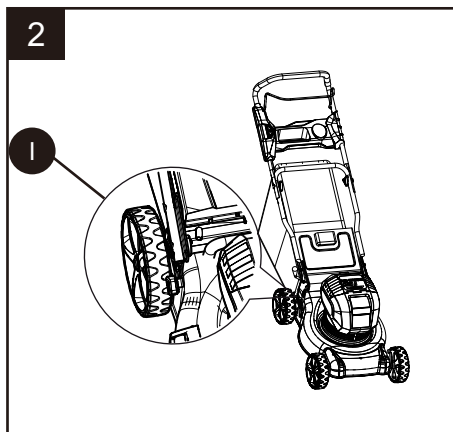



## MOWING TIPS

NOTE: A sharp blade will greatly enhance the performance of the mower, especially when cutting high grass. Be sure to check the blade and to sharpen it at least once per year.

- Verify that the lawn is free of stones, sticks, wires, and other objects that could damage the blades or the motor. These objects could be accidentally thrown by the mower in any direction, and could cause serious personal injury to the operator and to others. In order to prevent electric shock, do not operate the mower in damp or wet conditions.
- Do not mow in circles. Travel back and forth across the lawn.
- When cutting thick grass, reduce walking speed in order to allow for a more effective cut and a proper discharge of the clippings.
- For a healthy lawn, always cut one-third or less of the total length of the grass. The average lawn should be approximately 2.5 cm to 5 cm long during cool months, and between 5 cm to 8.5 cm long during hot months. If there is growth, the lawn should be cut in the fall.

## MULCHING TIPS

NOTE: Inspect the area where the mower is to be used and remove all stones, sticks, wire, bones, and other debris that might be thrown by the rotating blade.

- Release the switch to turn the mower OFF when crossing any graveled area (stones can be thrown by the blade).
- Set mower to the highest cutting height when mowing on uneven ground or in tall weeds.
- For effective mulching, do not cut wet grass because it tends to stick to the underside of the deck, preventing proper mulching of grass clippings. New or thick grass may require a narrower cut. The ground speed should be adjusted to the condition of the lawn. If mowing has been delayed and the grass has been allowed to grow longer than 10 cm, mow the lawn twice in order to reduce the grass height to a maximum of 8.5 cm.
- Walk at a steady pace. Overlap the cutting rows. Do not let the grass get too tall. If the grass gets too long, start at the highest cutting position and work down to the desired cutting height.



### WARNING

If you strike a foreign object, stop the motor and remove the battery. Thoroughly inspect the mower for any damage. Repair any damage before operating the mower. Excessive vibration of the mower during operation is an indication of damage. Thoroughly inspect the mower and repair any damage before operating the mower.

---

## EMPTYING THE GRASS CATCHER BAG (3)

Stop the mower and allow blades to completely stop.

- Lift the rear discharge cover.
- Lift the grass catcher by its handle to remove from mower.
- Empty grass clippings.
- Lift the rear discharge cover and reinstall the grass catcher as described earlier in this manual.

NOTE: When the grass catcher is bag full, the grass catcher bag needs to be emptied

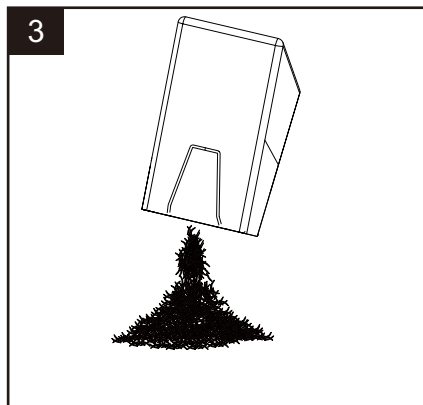

## BATTERY AND CHARGER

1

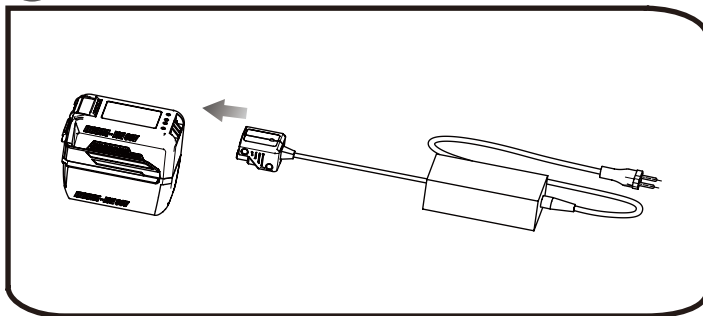

2

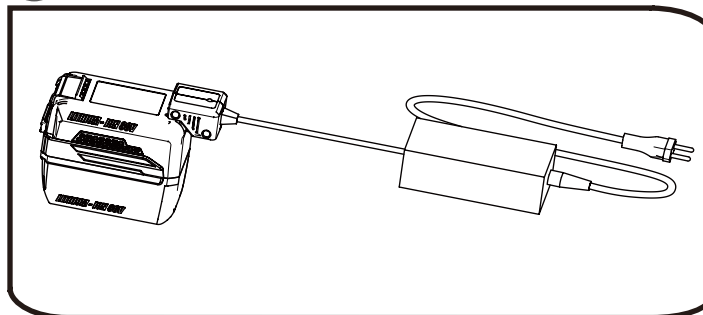

## CARE AND MAINTENANCE

### REPLACING THE CUTTING BLADE



#### WARNING

Always protect your hands by wearing heavy gloves and/or wrapping the cutting edges with rags or other materials when performing any maintenance on the blades. ALWAYS remove the battery when servicing or transporting the mower.

### REMOVE BATTERY

While wearing leather padded gloves, wedge a block of wood between the blade and the mower deck in order to prevent the blade from turning when the bolt (1) is being removed.

- Using an adjustable wrench or 27 mm socket, loosen the bolt (1) and remove the blade (2). Turn the bolt "COUNTERCLOCK WISE" to loosen it and "CLOCKWISE" to tighten it.
- Remove the bolt (1) and the blade (2).
- To re-install the blade, position the blade with the cutting edges toward the ground. Assemble the bolt as shown. Using a 27 mm socket or wrench, turn the blade nut "CLOCKWISE" in order to secure the blade.

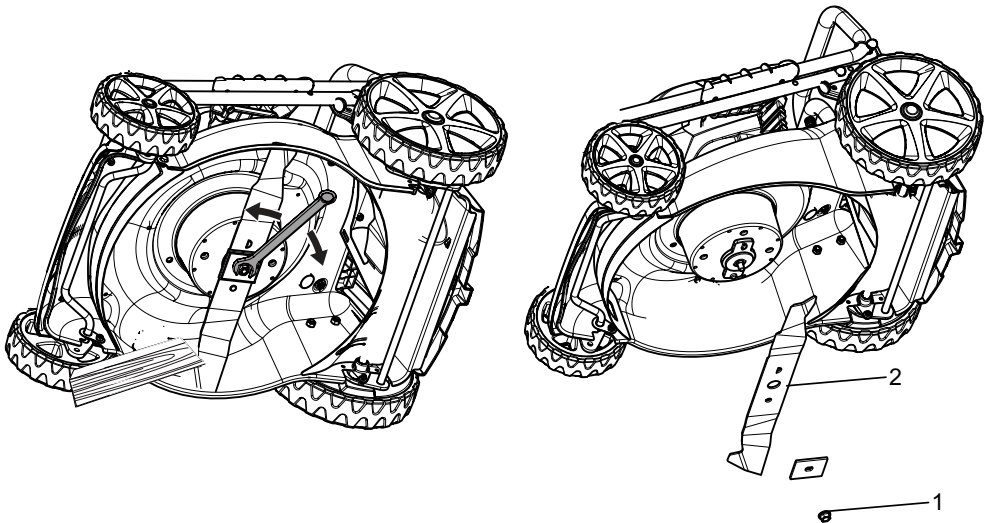

**NOTE:** Be sure to replace the parts in the exact order in which they were removed. When installing the cutting blade, verify that it is installed with the curved ends pointing toward the mower deck, and not toward the ground.

## CLEANING THE MOWER



### WARNING

In order to reduce the risk of electric shock, do not expose the mower to water. The underside of the mower deck should be cleaned after each use, because grass clippings, leaves, dirt, and other debris will accumulate, which will cause rust and corrosion.

Remove any build-up of grass and leaves on or around the motor cover (do not use water). Occasionally wipe the mower clean with a dry cloth. If debris builds up on the underside of the mower during use, stop the motor, disconnect it from the battery, and then tilt the mower on its side, and scrape it clean using an appropriate tool.

## SERVICE AND ADJUSTMENTS

- Identical replacement parts that are available from the manufacturer. In order to obtain replacement parts, the use of parts that do not meet the original equipment specifications may lead to improper performance, and may compromise safety.
- Before cleaning, repairing, or inspecting, verify that the blade and all moving parts have come to a complete stop. Remove the battery when making any adjustments or when any of the four wheels must be lifted off the ground.
- Keep the handles dry, clean, and free of oil and grease.
- In order to reduce the risk of fire, keep the motor free of grass, leaves, and debris build-up.
- Check the blade and motor mounting bolts for proper tightness frequently. Visually inspect blade for damage (e.g., bent, cracked, or worn).
- For best and safest performance, maintain the mower with care. Keep the mower blade sharp and clean. Mower blades are sharp, and can cut. Wrap the blades or wear gloves, and use extra caution when servicing.
- Keep all nuts, bolts, and screws tight in order to be sure that the equipment is in safe working condition.
- Never tamper with safety devices. Check them regularly for proper operation.
- After striking a foreign object, stop the motor. Thoroughly inspect the mower for any damage. Repair any damage before operating the mower.
- The grass catcher components, discharge cover, and trail shield are subject to wear and damage, which could expose moving parts or allow objects to be thrown. As a safety precaution, check these components frequently, and immediately replace any parts that show signs of wear, or that are cracked or broken. Use original equipment manufacturer's parts only.
- When it is not in use, store the mower indoors in a dry area, and out of the reach of children.



### WARNING

Always remove battery when servicing or transporting the mower.

PROBLEM	POSSIBLE CAUSE	SOLUTION
The mower does not start.	The battery is not charged.	Charge the battery.
	The switch is defective.	Replace the switch
	Grass jammed between the deck and blade.	Remove battery; check under deck for jams.
	The battery is not fully inserted in the mower.	Check the connection between the battery and the mower. Make sure the battery clicks into place.
The mower cuts the grass unevenly.	Battery may require service or replacement.	Replace battery.
	The lawn is rough or uneven.	Check the mowing area.
The mower does not mulch properly.	The cutting height is not set properly.	Move the wheels to a higher setting.
	Wet grass clippings are sticking to the underside of the deck.	Wait until the grass dries before mowing.
The mower is hard to push.	The mulching plug is missing.	Install the mulching plug.
	The grass is too tall, or the cutting height is too low.	Raise the cutting height.
The mower is excessively noisy and vibrates.	The rear of the grass catcher bag is dragging in thick grass.	Empty the grass clippings from the grass catcher bag.
	The motor shaft is bent.	Stop the motor, and inspect for damage.
	The blade is unbalanced.	Repair before restarting.

## TRANSPORTING LITHIUM BATTERIES

Transport the battery in accordance with local and national provisions and regulations. Follow all special requirements on packaging and labelling when transporting batteries by a third party. Ensure that no batteries can come in contact with other batteries or conductive materials while in transport by protecting exposed connectors with insulating, non-conductive caps or tape. Do not transport batteries that are cracked or leaking. Check with the forwarding company for further advice.

## RECYCLING AND DISPOSING

When you decide to get rid of the machine, make sure to follow the local regulation. The batteries used in this mower's battery pack contain the following toxic and corrosive material: LITHIUM-ION.



### WARNING

Toxic materials must be disposed of in a specified manner in order to prevent contamination of the environment. Before disposing of damaged or worn out Lithium-Ion battery packs, contact your local waste disposal agency for information and specific instructions. Take the battery to a local recycling and/or disposal centre that is certified for disposal. If the battery pack cracks or breaks, whether it leaks or not, do not recharge it and do not use it. Dispose of it and replace it with a new battery pack. **DO NOT ATTEMPT TO REPAIR IT!**

Follow these instructions in order to avoid injury and the risk of fire, explosion, or electric shock, and to avoid damage to the environment:

- Cover the battery's terminals with heavy-duty adhesive tape.
- Do not attempt to remove or destroy any of the components of the battery pack.
- Do not attempt to open the battery pack.
- If a leak develops, the electrolytes that are released are corrosive and toxic. Do not get the solution in the eyes or on the skin, and do not swallow it.
- Do not place batteries in regular household trash.
- **DO NOT** incinerate batteries.
- **DO NOT** place batteries where they will become part of any waste landfill or municipal solid waste stream.
- Dispose of batteries at a certified recycling or disposal center.

Package materials are recyclable. Please, throw them away in the appropriate trash can.

## GUARANTEE

This product has a 2 year guarantee. This guarantee is only valid if the product has not been used correctly and all the instructions have been followed.

In order to prove guarantee a receipt must be presented. The product has to be complete and have all its parts.

The guarantee does not cover wear, lack of maintenance, negligence, incorrect assembly and inappropriate usage (blows, disrespect to power supply, storage, using conditions, etc).

The guarantee is void when non original accessories or parts, have been used on the product.