

# LawnMaster®

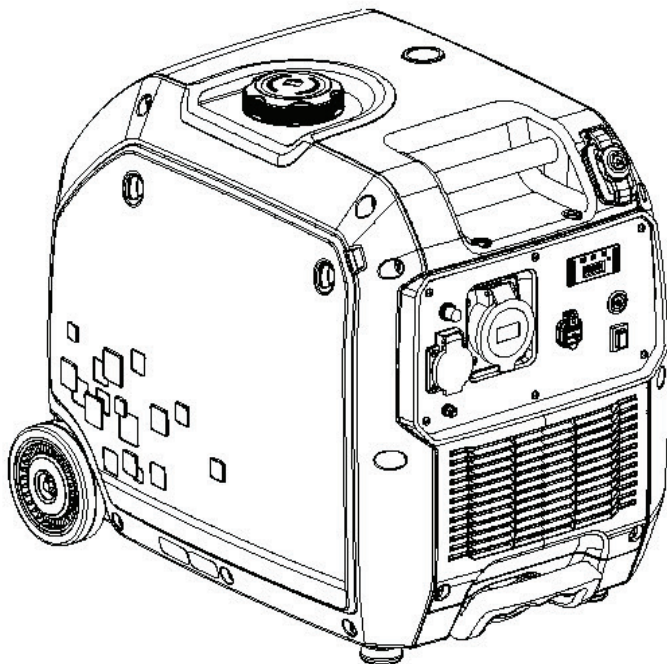

## SILENT INVERTER GENERATOR

### SAFETY AND OPERATING MANUAL

PLEASE READ THIS MANUAL CAREFULLY BEFORE OPERATING THE UNIT

## LGBQH6200(E)



A STEELFORT PRODUCT



PROUDLY  
NZ OWNED



## TABLE OF CONTENTS

<b>OPERATOR SAFETY</b>	<b>3</b>
<b>GETTING STARTED</b>	<b>5</b>
Unpacking	
Usage Of Handle	
Handle Reset	
<b>FEATURES &amp; CONTROLS</b>	<b>6</b>
Control Panel	
<b>OPERATION</b>	<b>9</b>
Operation Checklist	
Operation Conditions	
Engine Oil	
Engine Fuel	
Operation Place	
Grounding	
LGP Cylinder Check	
Inspection Of Connection With LGP	
<b>STARTING THE GENERATOR</b>	<b>11</b>
Recoil Start	
Electric Start	
LGP	
<b>CONNECTING TO THE ELECTRICAL DEVICES</b>	<b>14</b>
Loading Capacity	
Wattage Reference Chart	
<b>STOPPING THE ENGINE</b>	<b>15</b>
<b>MAINTENANCE</b>	<b>15</b>
Maintenance Schedule	
Generator & Engine Maintenance	
Air Filter	
Spark Plug	
Spark Killer	
<b>STORAGE &amp; TRANSPORT</b>	<b>20</b>
<b>TROUBLESHOOTING</b>	<b>21</b>
<b>SPECIFICATIONS &amp; WIRING DIAGRAMS</b>	<b>22</b>
<b>WARRANTY</b>	<b>24</b>

# OPERATOR SAFETY

## SAFETY RULES

This manual contains important safety information and instructions to operate the LawnMaster Inverter Generator.

PLEASE READ THIS MANUAL CAREFULLY BEFORE USING THE UNIT.

Failure to adhere to the safety instructions could result in property damage and/or serious personal injury.

This manual should be considered a permanent part of the generator and should remain with the unit at all times. All information in this publication is based on the latest product information available at the time of printing.

Product Information and specifications can be altered and/or improved without notice. Content from this publication may not be reproduced without written consent.

## DANGER

Indicates a hazardous situation which, if not strictly complied with, will result in substantial property damage and or serious injury.

## WARNING

Indicates a hazardous situation which, if not strictly complied with, may result in property damage

## CAUTION

Indicates a hazardous situation which, if not strictly complied with, could result in property damage or personal injury.

The warnings and precautions discussed in this manual does not cover all possible conditions and or scenarios that may occur.

It must be understood by the operator that common sense and caution must be taken into consideration when operating this product, as these are factors which cannot be built into this manual.

## WARNING

This generator is intended for domestic consumer use only. Damage and faults created from commercial use may void warranty. These generators are designed for full time operation. No personal modifications should be made to any part of the unit.

## DANGER

### TOXIC FUMES

- The exhaust of the engine contains carbon monoxide, an odorless, colorless poison gas. Using the engine in confined/indoor spaces can be extremely dangerous and life threatening.
- DO NOT use the generator inside and or in enclosed spaces EVEN IF doors and windows are open. Only use the engine in well ventilated areas and consider wind and airflow when positioning the engine.

### KICKBACK

- Rapid retraction of the starter cord will pull hand and arm towards the engine faster than you can let go. Unintentional startup can result in serious injury.

### FIRE

- When operating the unit, the engine may create sparks that could trigger fires.
- When operating around dry vegetation such as agricultural crops, forest, bush, grass, or other similar environments please be careful.
- This engine may not be equipped with a spark arresting muffler. In some countries and regions, a spark arrester is required by law. Please contact your local council and or fire agency for laws and regulations relating to fire prevention requirements.
- Petrol is highly flammable and explosive. A fire and or explosion from petrol can cause severe burns or result in serious personal injury including death.
- Keep flammable items away while handling petrol. Fill fuel tank outdoors and in a well ventilated area with the engine stopped.
- Always wipe spilled fuel and wait until the fuel has dried before starting the engine.
- DO NOT operate the engine with known leaks in the fuel system. Use proper fuel storage and handling procedures.
- DO NOT store fuel or other flammable materials near the generator.

- Empty the fuel tank before storing or transporting the generator. Keep fire extinguisher handy at all times.

### **BATTERY**

- Lithium battery is maintenance free, if you have any question, please contact a local LawnMaster dealer.

### **HOT SURFACE**

- Running the generator will produce heat and severe burns may occur upon contact. DO NOT touch the engine while under operation or just after stopping the unit.
- Avoid contact with hot exhaust gases and or hot surfaces.
- Maintain at least 1m of clearance on all sides to ensure adequate cooling. Combustible material can catch fire upon contact. Maintain at least 3m of clearance from combustible materials.

### **MOVING PARTS**

- Moving parts can cause severe injury. Keep hands and feet away from the unit.
- DO NOT operate engine with covers, shrouds, or guards removed.
- DO NOT wear loose-fitted clothing, dangling drawstrings or items that could become caught or entangled.
- Tie up long hair and remove jewelry. The moving parts may catch operator's hand, feet, hair and or loose clothing resulting in serious injury.

### **GENERAL WARNINGS**

- Before use, check for loose or damaged parts, signs of oil or fuel leaks, and any other condition that may impact operation.
- Repair or replace all damaged and or defective parts immediately.
- Locate all operating controls and safety labels.
- Make sure all the safety instructions are in correct working condition.
- Operate only on level surfaces.
- DO NOT expose the generator to excessive moisture, dust, and or dirt.
- Keep all safety guards in place and in proper working order at all times.
- DO NOT allow any material to block the cooling slots.
- DO NOT allow children or untrained people to operate the unit.
- DO NOT leave the generator unattended when

it is in operation. Always turn off the generator prior to leaving the area.

### **ELECTRIC SHOCK**

- The generator produces powerful voltage and the electricity and can be dangerous and cause serious life threatening injuries if an electric shock is received.
- Please ensure that the unit is properly connected to an appropriate ground to help prevent electric shocks.
- Failure to properly ground the unit can result in electrocution, especially if the generator is equipped with a wheel kit. Consult an electrician for local grounding requirements.
- Installation should be performed by a certified electrician. Improper Installation could result in serious injury.
- To reduce the risk of electric shocks. DO NOT use electrical cords that are worn, frayed, bare or otherwise damaged.
- DO NOT touch bare wires or receptacles.
- DO NOT operate the unit in wet weather.
- Keep the generator dry and DO NOT handle generator or electrical cords while standing in water, while barefoot, or while hands or feet are wet.
- Keep children or pets away.
- DO NOT plug the unit into a building electrical system without the proper use and installation of a transfer switch installed by a qualified electrician.
- When using the generator for backup power, notify your utility company.
- Use approved transfers to isolate generator from electric utility.
- Failure to isolate the unit from the power utility could result in serious injury to the staff and utility workers due to back-feed of electrical energy.

## **GETTING STARTED**

### **UNPACKING**

Remove the generator from the packaging

1. Place box on a solid and flat surface
2. Carefully cut each corner of the packaging box from top to bottom. Lay each side open and flat on the ground.
3. Remove all accessories except the generator from the packaging box.

### The following steps apply to electric start:

1. Connect the battery cable before the first use.
2. Unscrew the fixing bolt on the right maintenance panel and remove the maintenance panel.
3. Connect the battery harness, put the right maintenance panel back in place, and tighten the bolts.

Also, make sure that the combination switch lever is not pressed down by the right maintenance panel when installing the right maintenance panel back into place.

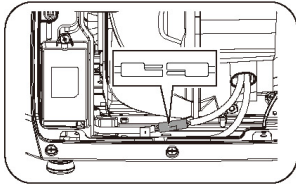

### HANDLE RESET

Press the handlebutton and hold the lever, push it inward towards the generator to the original position until the handle makes a "click" sound, indicating that it has been reset.

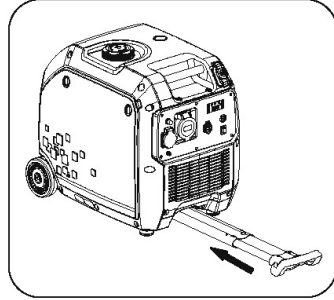

### USAGE OF HANDLE

#### CAUTION

Make sure the generator is placed on a level ground before using the handle.

After the handle button is pressed, the telescopic handle will pop out automatically; hold the lever and pull out the handle. The handle makes a "click" sound indicating that it has been pulled out completely, and in this case, the generator can be moved.

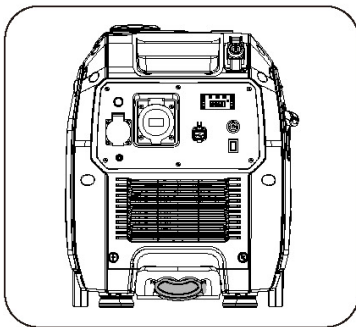

# FEATURES & CONTROLS

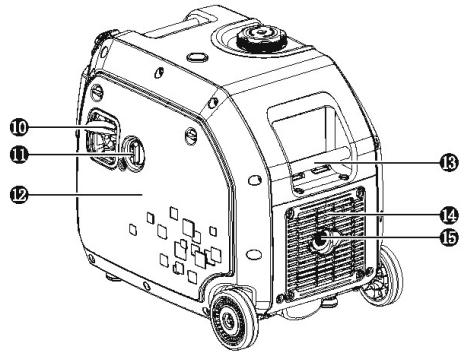
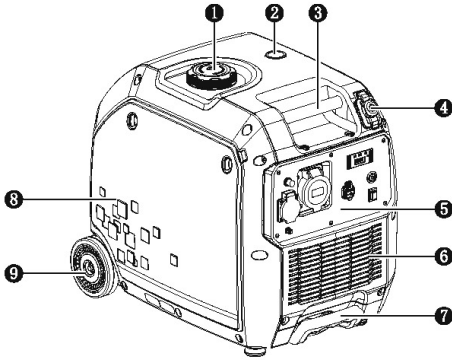

- |  |                                  |   |
|--|----------------------------------|---|
| <b>1. Fuel Cap</b>                         | <b>6. Air Inlet Screen</b>       | <b>11. Combination Switch</b><br>(Start (If Equipped), Run, Shut-Off, And Flameout) |
| <b>2. Fuel Level Indicator Sight Glass</b> | <b>7. Lever</b>                  | <b>12. Right Maintenance Panel</b>  |
| <b>3. Front Lift Handle</b>                | <b>8. Left Maintenance Panel</b> | <b>13. Rear Lift Handle</b>   |
| <b>4. Fuel Port (If Equipped)</b>          | <b>9. Wheels</b>                 | <b>14. Muffler Screen</b>   |
| <b>5. Panel Assembly</b>                   | <b>10. Start Handle</b>          | <b>15. Muffler</b>  |

## CONTROL PANEL

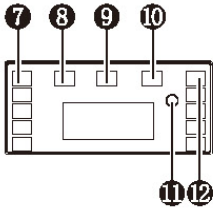
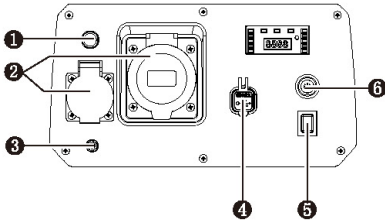

- |                                      |
|--------------------------------------|
| <b>1. Overcurrent Protector</b>      |
| <b>2. AC Output</b>                  |
| <b>3. Ground Terminal</b>            |
| <b>4. Usb Port</b>                   |
| <b>5. Energy-Saving Switch</b>       |
| <b>6. Push Button</b>                |
| <b>7. Load Indicator Light</b>       |
| <b>8. Overload Indicator Light</b>   |
| <b>9. Operation Indicator Light</b>  |
| <b>10. Oil Indicator Light</b>       |
| <b>11. Reset Button</b>              |
| <b>12. Oil Level Indicator Light</b> |

### OVERLOAD INDICATOR (RED)

When the overload indicator is on, it indicates that the generating set is overloaded and then the AC circuit breaker has tripped. It will stop the power output of generating set to protect the electric equipment and the generator set itself. At this time, the running indicator (green) is off and the overload indicator (red) is on, but the engine is still in running state.

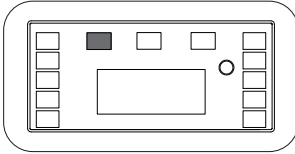

When the generating set has no output and the overload indicator is on, please take the following steps:

1. Lower the total load of the connected electric devices to the rated output range of the generator.
2. Check the air filter to ensure it is not clogged and the generator is in an open area to allow enough air flow to the generator.
3. Press the reset button.

### RUNNING INDICATOR (GREEN)

The running indicator lights up when generating set starts and has normal output.

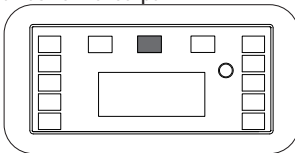

### OIL ALARM LAMP (YELLOW)

When the oil level drops below the lower limit, the oil protection system will stop the engine automatically and oil alarming lamp will blink when recoil starter is pulled. The engine will not run until the oil has been filled to the proper level.

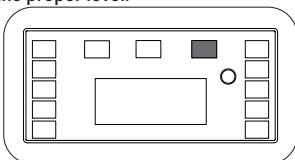

Note: If engine stalls or fails to start, turn the combination switch to "RUN" position and then pull the recoil starter. If the oil alarming lamp lights up, it shows lack of oil. Please add appropriate oil and restart the engine.

### RESET BUTTON

The reset button is used to restore output if an overload occurs. To restore output, reduce the load(s) and press the reset button.

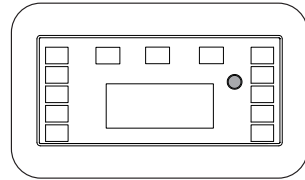

### ENERGY-SAVING SWITCH

When the energy-saving switch is in "ON" position, the energy saving equipment controls the engine rpm according to the connected loads. There will be good fuel consumption and low noise. When the energy-saving switch is in "OFF" position, the engine will always run at full rpm no matter what load is connected to it.

Note: Please set the energy-saving switch to "OFF" position when connect to an air compressor, pumps, circular saws etc., Due to large starting current required.

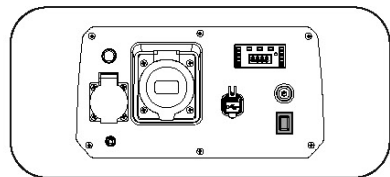

### GROUNDING TERMINAL

The grounding terminal is designed to prevent electric shock by connecting it to the grounding wire. The generating set must be properly grounded before operation.

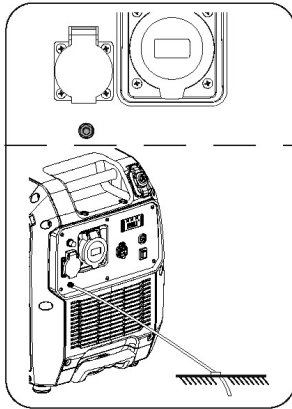

## OVERCURRENT PROTECTOR

When the generator is overloaded or overheated for a long time, the overcurrent protector will disconnect the output; in this case, please reduce the load or run it under no load for a few minutes, and then press the overcurrent protector button to restore the output.

Note: The overcurrent protector is relevant to the operating current, ambient temperature and other factors, so the protection time will be different.

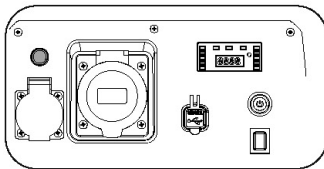

## COMBINATION SWITCH

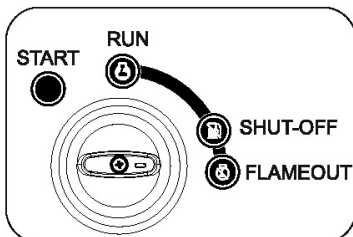

Note: After the generator is unloaded, please run for 3 minutes with no load to stabilize the temperature, then stop the generator.

SHUT Off: Fuel shut off valve. This position can run out of the remaining fuel to ensure old fuel is not present when generator has not been used for long periods.

Note: If you do not plan to use the generator in the near future, please use this function, or drain the fuel inside the carburettor using the drain bolt on the carburettor bowl.

FLAME OUT: The Generator stops working

Note: After the load is removed from the generator, please run the generator under no load for 3 minutes to balance the temperature, and then activate the flameout function

## LPG FEMALE CONNECTOR (IF APPLICABLE)

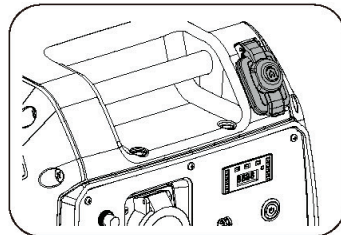

Open the LPG waterproof cover, align the male joint of the relief valve pipe with the LPG female joint and insert it until a click is heard, indicating that the relief valve is firmly connected. After the relief valve is firmly connected, the carburetor will stop supplying fuel and the generator can only use fuel at this time.

NOTE: If the generator needs to use the fuel, please close the fuel cylinder valve and disconnect the relief valve from the generator, and then the generator can use the fuel normally.



# OPERATION

## 1. OPERATING CHECKLIST

### OPERATING LOCATION

Only use this generator OUTSIDE and in well ventilated areas.

Only operate the generator on a flat, level surface and in a clean, dry operating environments. Only use the generator for applications within its operating scope. If you have any question regarding applicable scope, please speak to your nearest LawnMaster Service Dealer.

In some locations and regions, the generator may require additional provisions and or regulations for operation, please consult with your nearest Service Agent.

### DANGER

### TOXIC FUMES

The exhaust of the generator contains carbon monoxide, using the engine indoors may cause serious personal injury including death. DO NOT use the generator inside any buildings or within enclosed spaces EVEN IF doors and windows are open. Place the generator in a well-ventilated and clean area. Note the wind direction and airflow when placing the generator.

### HIGH ALTITUDE

This generator may require a high altitude carburetor kit to ensure correct operation at high altitudes. Consult with your local LawnMaster dealer for high altitude kit information if you intend to operate the generator at altitudes above 5,000 feet (1,500 meters).

### CAUTION

- Even with carburetor modification, generator horsepower will decrease by 3.5% for every 1,000 feet (300 meters) increase in altitude. The effect of altitude on horsepower will be greater than this if no carburetor modification is made.
- Operating the engine at altitudes below 5,000 feet (1,500 meters) with a modified carburetor may cause the generator to overheat and result in serious engine damage. Please restore factory specifications of the carburetor with your LawnMaster service dealer when using the engine in low altitude areas.

## 2. OPERATING CONDITION

Check for loose or damaged parts, signs of oil or fuel leaks, and any other condition that may affect proper operation. Repair and or replace with genuine spare parts immediately.

### WARNING

- Failure to correct problem(s) before operation may result in property damage and or serious personal injury.
- Remove excessive dirt or debris, especially around the muffler and recoil starter.
- DO NOT move or tip the generator during operation.

## 3. ENGINE OIL

- Place the engine on a level surface with engine stopped. Check the engine oil level.
- Remove the oil maintenance cover.
- Remove the dipstick and wipe it clean.

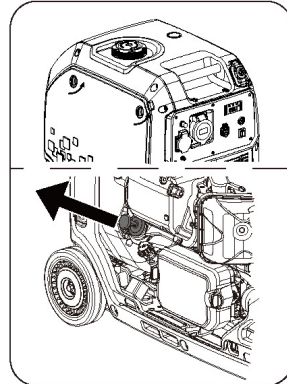

- Reinstall dipstick into hole; rest on oil fill neck, DO NOT thread cap into hole.
- Remove the dipstick again and check oil level. Level should be between the upper and lower limit

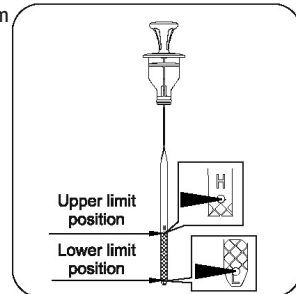

- Fill to the upper limit of the dipstick with the recommended oil if the oil level is too low.

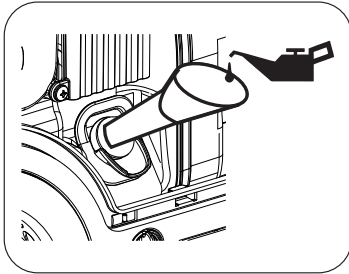

Reinstall and fully tighten the dipstick.  
Refer to add oil instruction in MAINTENANCE section for more information.

Oil level: 0.85 L  
Recommended grade of engine oil: SAE10W-30

#### WARNING

- Oil is a major factor affecting performance and service life.
- We recommend using LawnMaster 4-Stroke 10W30 Oil (PP01020005). You can find more information about this in the MAINTENANCE section of this manual.
- **OIL MUST BE PLACED IN ENGINE BEFORE STARTING.** This engine is not filled with oil at the factory. Any attempt to crank or start the engine before it has been properly filled with the recommended type and amount of oil may result in engine damage and void your warranty.

#### CAUTION

Operate generator only on level surfaces. The engine is equipped with a low oil sensors (if applicable) that will automatically stop the engine when the oil level falls below safe threshold. To avoid the inconvenient unexpected shutdowns, fill to the upper limit and check oil levels regularly.

#### 4. ENGINE FUEL

- With the engine stopped, check the fuel level gauge. Refill the fuel tank if necessary.
- Use clean, fresh, regular unleaded petrol.
- DO NOT mix oil with petrol.
- Always wipe up any spilled fuel.
- Be sure not to fill above the upper limit mark
- Always allow room for fuel expansion.
- DO NOT use engine and or carburetor cleaning

products in the fuel tank as this could result in permanent damage.

- It is important to prevent gum deposits from forming in essential fuel system components, such as the carburetor, fuel filter, fuel hose or tank during longterm storage. Also, experience indicates that alcohol-blended fuels (gasohol, ethanol or methanol) can attract moisture, which could lead to separation and formation of acids during longterm storage.
- Acidic fuels can damage the fuel system while in storage. Be sure to review the instructions in the "Storage" section.
- Petrol/Alcohol Blends: up to 10% alcohol, 90% unleaded petrol by volume is approved as a fuel. Other forms of petrol/alcohol blends are not approved.
- Damage and faults caused by old, stale or contaminated fuel may void warranty.

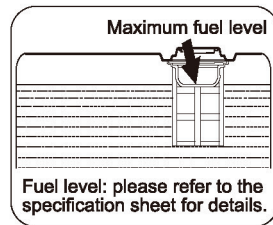

#### DANGER

- Do not fill the fuel tank above the upper limit. Over filling will result in engine damage and may void warranty.
- Petrol is highly flammable and extremely explosive. Keep flammable items away while handling petrol as this could result in a fire.
- Fill fuel tank outdoors and well-ventilated areas with the generator stopped.
- Always wipe off spilled fuel and wait until the fuel has dried before starting the generator.

#### CAUTION

- To minimise gum deposits in your fuel system and to insure easy starting, do not use petrol that is left over from the previous seasons.
- Pressure can build up in the fuel tank. Allow the generator to cool for at least two minutes before removing fuel cap. Loosen the fuel cap slowly to relieve any pressure in the tank.

#### 5. OPERATION PLACE

Before starting the generator, disconnect the electrical device from the generator and turn off

the circuit breaker. It may be difficult to start the generator after the electrical device is connected. The electrical device to be connected must not exceed the maximum power range of the generator. Refer to the specification sheet for details.

## 6. GROUNDING

- The generator must be properly connected to an appropriate ground. It helps prevent electrical shock if a ground fault condition exists in the generator or in connected electrical devices, especially when the unit is equipped with a wheel kit. Proper grounding also helps dissipate static electricity, which often builds up in ungrounded devices.

### **DANGER**

#### **ELECTRICAL SHOCK**

Failure to properly ground the generator could result in electric shocks.

A ground terminal on the frame of the generator has been provided and can be found on the end of the generator. For remote grounding, connect a (4 mm<sup>2</sup>) length of heavy gauge copper wire between the generator ground terminal and the copper rod driven into the ground.

The National Electrical Code requires that the frame and external electrically conductive parts of this generator be properly connected to an approved earth ground. Local electrical codes may also require proper grounding of the unit. We strongly recommend that you consult with a qualified electrician for grounding requirements in your area.

## 7. LPG CYLINDER CHECK

LPG is stored in special fuel cylinders. Inspect the fuel cylinder for sufficient LPG before using LPG. Inspect if there is a risk of fuel leakage, and if so, replace with a safe fuel cylinder with sufficient LPG immediately.

### **CAUTION**

Before using LPG, please check the thread connection between LPG cylinder and the pressure relief valve is well.

## 8. INSPECTION OF CONNECTION WITH LPG

Connect one end of the relief valve to the fuel

cylinder and the other end to the LPG female joint of the panel. Moisten the connector with soapy water and start the generator. Inspect all connectors for leaks. If bubbles appear and become larger, it indicates that any connector is not installed in place or is damaged, resulting in leakage. Please close the fuel cylinder valve and turn off the generator immediately, reinstall the connector or replace it with an undamaged one. If the leak is not resolved or the leak is not on the connector, please stop using the generator immediately and contact your local dealer.

### **DANGER**

#### **FIRE OR EXPLOSION**

LPG is a flammable and explosive substance. It is forbidden to lay the LPG cylinder by lying it down, and the fuel cylinder shall be kept in an upright position when being used. If the fuel cylinder leaks, the generator shall be immediately shut down, and the leaking fuel cylinder shall be replaced with another one, to ensure there is no risk of leakage after the replacement. Then the generator can be restarted. It is forbidden to put the fuel cylinder close to the fire or heat. Minors are prohibited from cylinder and using the equipment. Please use the LPG cylinder that meets the national standard. Please provide the fire extinguisher nearby for use in case of fire.

## STARTING THE GENERATOR

1. Pull the starter handle 6-8 times to prefill fuel system before initial operation or removal from long term storage. Failure to do so could result in bad starting experience.
2. The following are suitable for Recoil Start & Electric Start

### **COLD START**

Turn the combination switch to "START" position.

### **WARM START**

Turn the combination switch to "RUN" position, if not started, please turn the combination switch to "START" position before restarting.

Suitable to start by Push Button

Turn the combination switch to "RUN" position

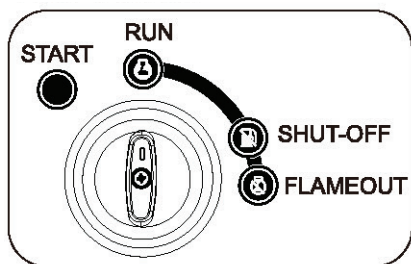

3. Select according to the actual configuration of the user

### RECOIL START

To start the generator, hold the handle of the recoil starter and pull it slowly until there is resistance and then quickly pull the handle to start the generator.

#### WARNING:

Please check the condition of the starter rope before use. If the rope is seriously worn, please replace it at the authorized local dealer in time.

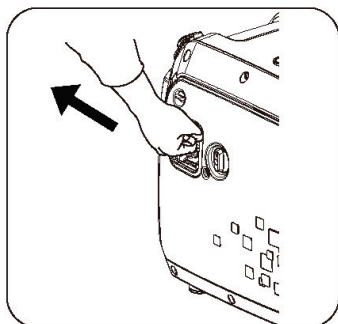

#### WARNING - RECOIL

When the recoil starter retracts quickly after start-up, the hand and arm will be pulled toward the engine faster.

Unpreparedness may result in accidental injury.

#### CAUTION

During start-up, the choke may be affected by temperature or other factors and may require different openings.

### ELECTRIC START {IF CONFIGURED}

Press and hold the start button for 0.3-5 s and then release it, and the generator will be started, and the start button will be reset automatically.



#### WARNING

When the generator cannot be started through electric start due to low battery power, which is caused by generator idling for a long time or in improper use, please manually control the damper and start the generator according to the steps for recoil start. The generator will automatically charge the battery after normal operation.

### PUSH BUTTON (IF CONFIGURED)

Push the button once to start the generator

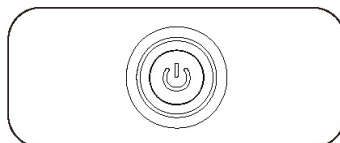

#### CAUTION

After the generator is used for a period of time, if the push speed of the motor decreases, it means that the battery needs to be replaced. Before shutting down the generator, ensure that the combination switch in "Flameout" position, to prevent battery power loss, which may affect the next start.

If the generator still fails to be started or is shut down after three attempts, find the cause of the fault and eliminate it.

The engine oil alarm prevents the generator from being started when the oil level in the crankcase is below the lower limit.

Before the operation, please do a routine inspection of the oil. The recommended maintenance interval can be found in the maintenance section.

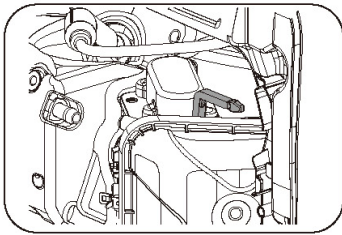

### CAUTION

When the generator can not be started through the electric start, please open the left maintenance panel, and start the generator through the choke handle and the start handle together.

After completing the above operations, the generator can be connected to the electrical devices. When the electrical devices require high initial power, please turn the energy-saving switch to "OFF" position. When no more initial power is needed, please turn the energy-saving switch to "ON" position.

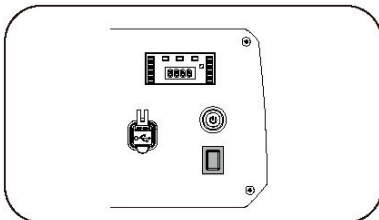
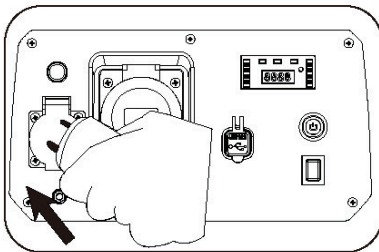

### WARNING

When the generator output terminal is connected to the electrical device and the electrical device is on, it is prohibited to start or shut down the generator.

### CAUTION

Do not continue to start the generator before the fault is removed. It is forbidden to start the generator after using other batteries without authorization.

### STARTING THE GENERATOR WITH LPG (IF EQUIPPED)

1. Perform pre-use inspection items and remove all loads
2. Connection steps of relief valve assembly, generator and fuel cylinder

Attach the relief valve hose assembly (threaded end) to the fuel cylinder valve and tighten it.

Remove the shields from the generator LPG female connector and relief valve pipe male connector.

Align the upper male connector of the relief valve pipe with the generator LPG female connector and insert it until you hear a "click" sound, indicating that the relief valve pipe and the generator LPG female connector are firmly connected.

3. Open the fuel cylinder valve
4. Select according to the actual configuration of the user

### RECOIL START

1. Before starting the generator, turn the combination switch to "START" position.
2. Hold the handle of the recoil starter and pull it slowly until there is resistance, and then quickly pull the handle to start the generator.

### ELECTRIC START

Press and hold the start button in "ON" position for 0.3-5 s and then release it, and then the generator will be started.

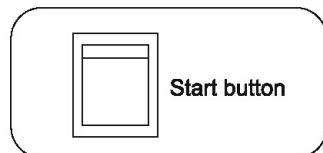

Push by push button

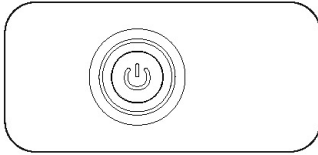

Suitable for recoil start and electric start  
After the generator is started, turn the combination switch to "RUN" position. After the above operation, the generator can be loaded.

## CONNECT TO ELECTRICAL DEVICES

Inspect power cord for damage before using. A hazard is electrical shocks from crushing, cutting or heat damage.

1. Confirm that the generator is grounded. If the electric device requires grounding, the generator must be grounded.
2. Ensure that all electrical devices are turned off.
3. After the generator is started, let it run for a few minutes to allow it to warm up to a steady state.
4. Confirm the connection and then turn on the electric device you expected.
5. Before stopping the generator, please turn off the electrical device or disconnect the output.
6. If the generator provides power to more than one electrical devices, start each electrical device according to the size of the load, from small to large.

### DANGER

If connected devices overheat, turn them off and disconnect them from generating set.

### ELECTRICAL SHOCK

- To reduce the risk of electrical shock, DO NOT use electrical cords that are worn, frayed, bare or otherwise damaged.
- DO NOT touch bare wires or receptacles.
- DO NOT handle generator or electrical cords while standing in water, while barefoot, or while hands or feet are wet.

## LOADING CAPACITY

You must make sure your generator can supply enough rated (running) and surge (starting) watts for the electrical devices you plan to power at the same time. Follow these simple steps to calculate the running and starting watts that are necessary for your purposes.

### WARNING

- DO NOT overload the generator.
  - Exceeding the generator's capacity can damage the generator and/or electrical devices connected to it. Faults and damaged caused by overloading may void warranty.
1. Select the electrical devices you will power at the same time.
  2. The amount of power you need to run all the devices is the total rated (running) watts of these items.
  3. Identify how many surge (starting) watts you will need. Surge wattage is the short burst of power needed to start electric power tools and or appliances. Because not all motors start at the same time, total surge watts can be estimated by adding only the electrical device(s) with the highest additional surge watts to the total rated watts from step 2.

## WATTAGE REFERENCE CHART

Electric equipment		Rate power(W)	Starting power(W)
Appliances	Tablet TV 27"	80	100
	Energy saving lamp	5-50	5-50
	Electric cooker	1000	1000
	Computer	250	250
	Electric fan	50	100
	Washing machine	250	500
	Refrigerator	50	300
	Air-conditioner	1600	3200
Electric tooling	Electric hammer	1000	1500
	Impact Hammer	3000	6000
	Water pump	2200	5000
	Electric welding machine	5000	7500
	Air compressor	5000	10000

### WARNING

It is necessary to equip with circuit protector or switch to isolate the generating set from the electric utility when the generating set is mainly used for backup. Failure to isolate the generating set from the power utility may result in injury or death to electric utility workers and damage to the generating set due to back feed of electrical energy.

## STOPPING THE ENGINE

Turn off the electrical devices and then unplug all the electrical device plugs from the panel.

### WARNING

NEVER stop the engine with electrical devices connected and with the connected devices turned "ON".

### STOP USING GASOLINE

- Turn the combination switch to "SHUT-OFF" position. Let the generator burn off the excess fuel in the fuel circuit, and the generator will be automatically shut down.

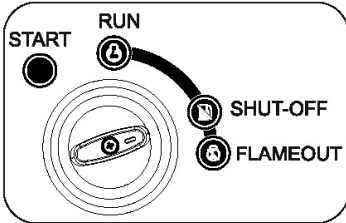

- Turn the combination switch to "FLAMEOUT" position.

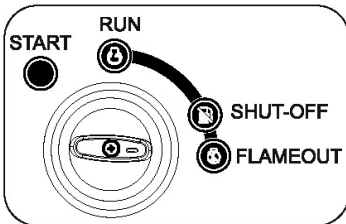

### WARNING

The generator is idle for a long time:  
If the generator needs to be idle for a long time, please turn the fuel cock to "Shut-off" position.

Turn the combination switch to "Flameout" position until the fuel in the carburetor oil cup burns out and the generator has an automatic flameout. If the combination switch is not turned to "FLAME-OUT" position and the battery is not in use for a long time, it will lose power, resulting in failure to start the generator normally.

### STOPPING WHEN USING LPG (IF APPLICABLE)

1. Let the generator run without load for 3 min to stabilize the internal temperatures of the engine and the generator.
2. Close the fuel cylinder valve.
3. Turn the combination switch to "FLAMEOUT" position.

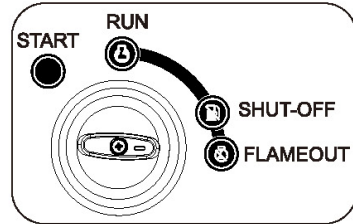

4. Remove the relief valve from the generator LPG female joint and cover it with the shield.

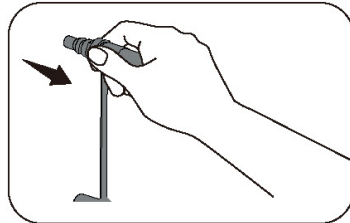

## VIII. MAINTENANCE

It is the operator's responsibility to complete all scheduled maintenance and or servicing in a timely manner. Always correct any issues before operating the generator. Follow all inspection and maintenance recommendations that are listed in the manual.

## WARNING

Improper maintenance and or failure to correct problems prior to operating the unit may cause the unit to malfunction and result in property damage and or serious personal injury. Improper maintenance and servicing may void warranty.

## DANGER

Accidental starts can cause serious personal injury. Remove and ground the spark plug wire before performing any service.

## CAUTION

The filter element may contain PAHs, PAHs that is harmful for your health. Please wear gloves for protection during air filter maintenance.

## 1. MAINTENANCE SCHEDULE

Before servicing the generator, stop the generator, disconnect all electric devices and battery (if equipped) and allow the generator to cool down.

operating in adverse conditions. Contact your local LawnMaster Service Dealer if the generator requires maintenance.

Follow the service intervals indicated in the chart below. Service your generator more frequently when

		Each time before use	The first month or 10 hours <sup>note2</sup>	Every three months or 50 hours <sup>note2</sup>	Every six months or 100 hours <sup>note2</sup>	Every year or 300 hours <sup>note2</sup>
Engine oil	Inspection	√				
	Replacement		√		√	
Air filter	Inspection	√				
	Cleaning				√ <sup>note3</sup>	
Spark plug	Inspection and adjustment				√	
	Replacement					√
Spark Extinguisher <sup>note1</sup>	Cleaning				√	
Idle speed	Inspection and adjustment					√ <sup>note4</sup>
Valve clearance	Inspection and adjustment					√ <sup>note4</sup>
Oil tube	Inspection	Every two years <sup>note4</sup>				

Note 1: Applicable types (if available).

Note 2: Before each season and after (whichever comes first).

Note 3: Service more frequently under severe, dusty, dirty conditions.

Note 4: To be performed by knowledgeable and or experienced owners. However, we recommend using an authorised LawnMaster service agent to conduct all maintenance and servicing need for the purpose of voiding issues with warranty.



## 2. GENERATOR MAINTENANCE

- Make certain that the generator is kept clean and stored properly.
- Use a damp cloth to clean exterior surfaces of the generator.
- Use an compressed air (25 PSI) to clear dirt and debris from the generator.
- Inspect all air vents and cooling slots to ensure that they are clean and unobstructed.

### WARNING

- DO NOT use water to clean the generator. Water can enter the generator through the cooling slots and damage the generator windings.
- DO NOT modify the generator in any way.
- DO NOT tamper with governed speed. Generator supplies correct rated frequency and voltage when running at factory set.
- Tampering with the factory reset governor will void your warranty

## 3. ENGINE MAINTENANCE

### 3.1 ENGINE OIL

LawnMaster 10W30 Oil (PP01020005) is recommended. Other viscosities shown in the chart may be used when the average temperature in your area is within the indicated range. **OIL MUST BE PLACED IN ENGINE BEFORE STARTING.**

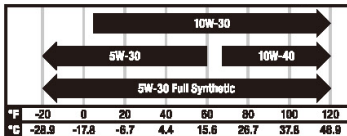

Ambient temperature

Oil capacity (rated):

See Parameters.

### 3.2 ADDING OIL

#### WARNING

The engine is not filled with oil at the factory. Any operation before it has been properly filled with the recommended type and amount of oil may result in engine damage and void your warranty.

1. Place the engine on a level surface.
2. Remove the air filter maintenance cover and dipstick and wipe it clean.

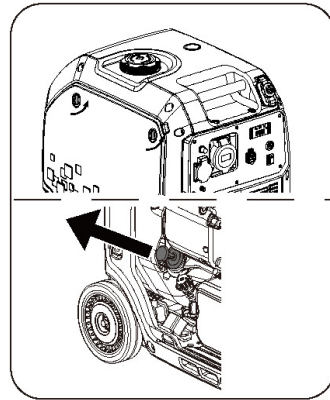

3. Add recommended oil to the upper limit.

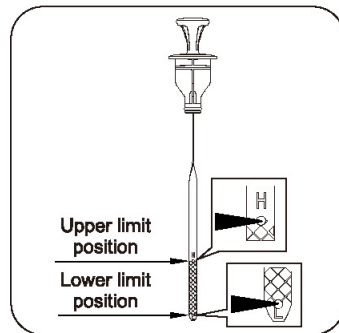

#### CAUTION

##### Inspection of the filling scale mark

Reinstall dipstick into hole; rest on oil fill neck. DO NOT thread cap into hole. Remove the dipstick again and check oil level. Level should be between the upper and lower limit.

4. Install the dipstick back to its original position and fix the left maintenance panel with fixing bolts.

### 3.3 CHANGING OIL

#### CAUTION

Change the oil when in hot engine state. The oil can reach up to 140 °C under that condition. Careful operation should be taken to prevent burns.

1. Place the machine on a level surface which is 300mm higher than the ground.
2. Remove the left maintenance panel after unscrewing the fixing bolts.

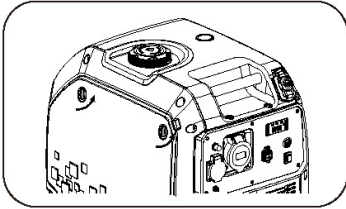

3. Place the waste oil box under the generator drain pipe outlet, release the drain pipe and unscrew the pipe plug so that the generator completely drains the oil to be changed. After draining the oil, refit the plug and drain pipe to their original positions.

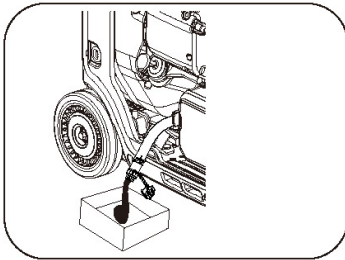

4. Remove the dipstick and wipe it clean.
5. Add the recommended oil to the upper limit
6. Fully tighten the dipstick and install the air filter maintenance cover back in place.
7. Properly dispose of any used oil at an approved waste management facility.

#### 4. AIR FILTER

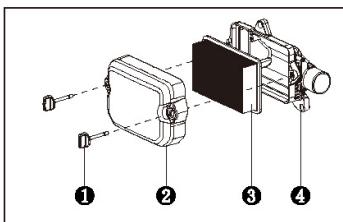

1. Air Filter Fixing Bolt
2. Air Filter Cover
3. Paper Air Filter Element
4. Air Filter Base

1. Loosen the filter fix bolt and remove the cover of the air filter.
2. Remove the foam filter element.
3. Wash in liquid detergent and warm water
4. Squeeze thoroughly dry in a clean cloth.
5. Saturate in clean engine oil.
6. Squeeze in a clean, absorbent cloth to remove all excess oil.
7. Place the filter in the assembly.
8. Fasten the air filter cover with the fix bolt, and the mounting it back to the air filter body.

#### WARNING

The air filter is a key part that affects the emission performance, and any form of modification is strictly prohibited. It is prohibited to use the engine without installing or correctly installing the air filter, otherwise the engine will be seriously worn or damaged, and the product warranty will be void. It is strictly forbidden to use organic solvent to clean the paper filter element, and to use compressed air to blow and clean it.

#### 5. SPARK PLUG

#### WARNING

Before repairing the spark killer, make sure that the engine has cooled down completely.

1. Remove the left maintenance panel after unscrewing the fixing bolt.
2. Clean any dirt from the spark plug cap and spark plug base.
3. Remove the spark plug cap.
4. Using socket wrench to loose and remove the spark plug

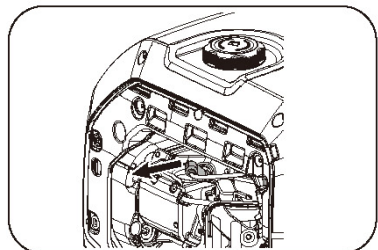

5. Inspect the spark plug and spark plug washer, if it's damaged or worn, replace with new one. Clean the spark plug with wire brush if reuse it.
6. Check spark plug gap. Carefully bend side electrode to adjust the gap if necessary.

**SPARK PLUG GAP: 0.6MM - 0.8MM**

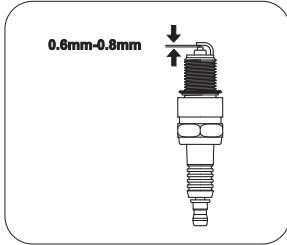

7. Carefully thread the plug into the engine by hand.
8. After the spark plug is in position, use spark plug wrench to tighten the plug.

**SPARK PLUG TIGHTEN TORQUE: 20-25 N.M**

9. Attach the spark cap to the plug and connect the spark plug wire to the plug.

**WARNING**

Only use the recommended spark plug or equivalent. DO NOT use spark plugs that have improper heat range.

10. Install spark plug maintenance cover.

**SPARK KILLER**

(IF APPLICABLE)

1. Allow the generating set to cool completely before servicing the spark arrester.
2. Remove the muffler blind window first.
3. Remove the spark arrester screen.
4. Carefully remove the carbon deposits from the spark arrester screen with a wire brush.
5. Replace the spark arrester if it is damaged.
6. Reinstall the spark arrester in the muffler and reinstall the muffler blind window.

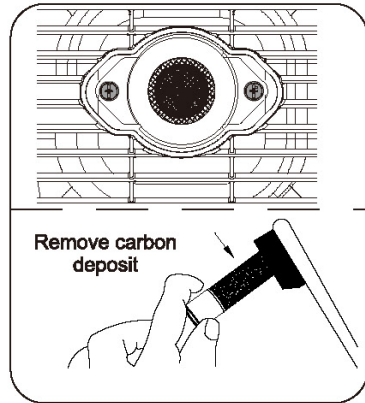

**SPEED**

The speed has been pre-set at the factory and should rarely require readjustment. Consult your local LawnMaster dealer for such needs.

**WARNING**

Unapproved adjustment will damage your engine and/or your electrical devices and void your warranty.

**ADJUSTMENT**

There has no other service and/or adjustment need for your generator. Unapproved adjustments or tampering can damage your generator and your electrical devices and will void your warranty. Contact your local LawnMaster dealer for such needs.

**WARNING**

Tampering with the factory set governor will damage your generator and void your warranty.

## STORAGE & TRANSPORTATION

### STORAGE

The generating set should be started at least once every 2 weeks and allowed to run for at least 20 minutes. Follow the instructions below for longer term storage if the generating set will be out of service for 2 months or more.

### WARNING

#### FIRE OR EXPLOSION

Gasoline is highly flammable and extremely explosive. Empty the fuel tank and shut off fuel valve before storing or transporting this generating set.

1. Allow the generating set to cool completely before storage.
2. Clean the generating set according to instructions in Maintenance section.
3. Drain all fuel completely from the fuel tank, fuel hose and carburetor to prevent gum from forming.
4. Turn the combination switch in "STOP" position to cut off the fuel.
5. Remove the oil drain plug to drain out the oil
6. Remove the spark plug and pour about 15 ml of fresh oil into the cylinder. Pull the recoil starter slightly to distribute the oil and lubricate the cylinder. And then attach the spark plug.
7. Store the unit in a clean, dry area out of direct sunlight.
8. Disconnect the battery.

### TRANSPORTATION

When generator is being transported or put into short term storage, the generator should be in the normal operating position and fixed vertically to prevent fuel leakage. The combination switch should be in the "stop" position and knob of the fuel cap should be turned to the "OFF" position.

### WARNING

When transporting do not overfill the tank. Do not operate the generating set while it is on vehicle. Take the generating set off the vehicle and use it in a well-ventilated place. Avoid a place exposed to direct sunlight when putting the generating set on a vehicle. If the generating set is left in an enclosed vehicle for many hours, high temperature inside the vehicle could cause fuel to vaporize resulting in a possible explosion. Do not drive on a rough road for an extended period with the generating set on board. If you must transport the generating set on a rough road, drain the fuel beforehand.

## TROUBLE SHOOTING

Failure	Trouble	Solution
Generating set fails to start	Turn the combination switch to "FLAMEOUT" or "OFF" position.	Turn the combination switch to "RUN" position, and then start the generator according to start steps.
	Lack of fuel.	Fill the fuel tank with fuel in accordance with the instructions in this manual.
	Lack of engine oil.	Check oil level. This engine is equipped with a low oil sensor. The engine cannot be started unless the oil level is above the prescribed lower limit.
	No ignition.	Remove the spark plug cap. Clean the dirt around the spark plug base, and then remove the spark plug. Insert the spark plug into the spark plug cap. Turn the combination switch to "RUN" position. Pull the recoil starter and observe whether there is any electric spark between the spark plug clearance. Replace the spark plug if there is no spark.  Follow the instructions in this manual to reinstall the spark plug and start the engine.  If necessary, please consult your local dealer.
	Spark plug is splashed by fuel	Remove the spark plug and wipe the fuel.
	Low battery power (electric start)	Manually start the generator to charge the battery (time≥30 min).
Generating set has no output	Overload protection	Reconnect the circuit breaker or overcurrent protector.
	Mismatched cable installation or extension cable	Inspect the load-carrying capacity of the end face of the cable installation or extension cable.  If necessary, please consult your local dealer.

# SPECIFICATIONS & WIRING DIAGRAMS

## 1. SPECIFICATION (PARAMETER TABLE)

Feature \ Model		BQH6200(E)	
Engine parameter	Engine model	GB300(E)-2	
	Style	OHV, forced cooling, four stroke, single cylinder	
	Displacement (cm <sup>3</sup> )	302	
	Ignition system	TCI	
	Start style	Hand recoil or electric starting	
	Oil capacity(L)	0.85	
Series parameter	Frequency(Hz)	50	60
	Voltage(V)	230	120/240
	Rated power(kW)	5.0	5.0
	Maximum power(kW)	5.5	5.5
	Power factor	1	
	Insulation rate	F	
	Fuel capacity(L)	13.5	
	Operating temperature(°C)	-10~40	
	Max. site altitude of installation(m)	1500	
	Measured sound pressure level(dB(A))	≤74	
	Measurement uncertainty(dB(A))	≤1.5	
	Guaranteed sound power level(dB(A))	≤95	
	Net weight(kg)	48.2 (manual start) 50.5 (electric start)	

Note: The generating set with different specification and configurations may have different parameters and may change at any time without notice.

## 2. WIRING DIAGRAMS

### BQH6200E ELECTRIC START

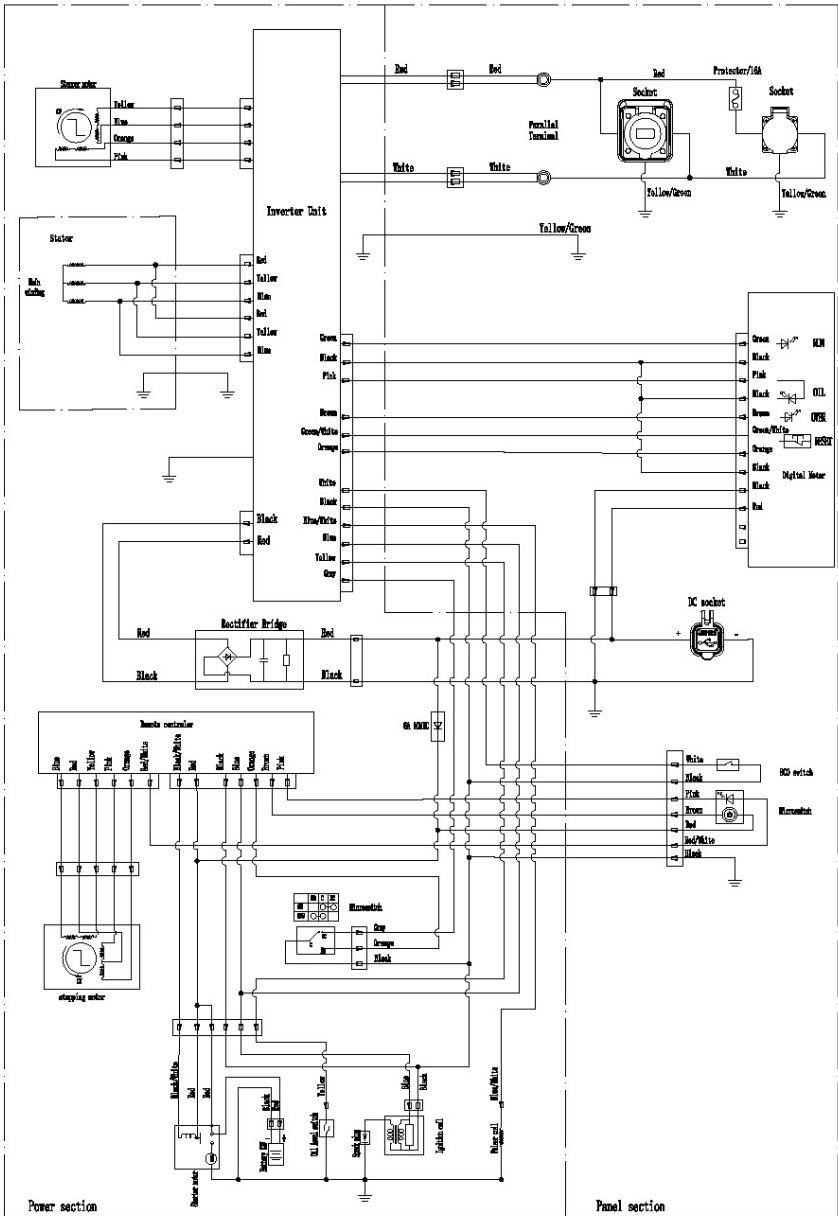

Note: This circuit diagram is for reference only due to the generator set condition difference

# WARRANTY

## 3-YEAR DOMESTIC CONDITIONAL WARRANTY

### UP TO 90 DAYS FOR COMMERCIAL USE.

LawnMaster Dealer extended warranty period for items that are:

- Registered at the time of sale.
- Serviced by an Authorised LawnMaster Service Dealer in accordance with the service schedule using Genuine parts and oils (proof required).
- Meeting all other warranty requirements.

## LAWNMASTER LIMITED WARRANTY

The warranty applies to all new LawnMaster products that are identified by their unit serial number.

In order to be eligible for the LawnMaster limited warranty, you must have, maintenance performed according to the schedule contained in the relevant owner's manual that is supplied with the product, and ongoing maintenance performed by an authorised LawnMaster dealer.

Steeffort will recognise your statutory rights under the Consumers Guarantee Act 1993. To ensure the safe operation of this product, we strongly recommend that you only use an authorised LawnMaster dealer for all maintenance and servicing requirements. Authorised LawnMaster Dealers have access to special tools, training, and genuine parts that are required to maintain your LawnMaster product for peak operating conditions. The purchaser must keep an accurate record of all service and maintenance. This may be requested when assessing any future warranty claims.

To qualify for the LawnMaster extended Warranty, a warranty registration must be completed online through the Steeffort website ([www.steeffort.co.nz](http://www.steeffort.co.nz)) within ten (10) days following the date of purchase.

Proof of purchase documentation are required and must include the engine serial number and frame serial number as appropriate for all warranty claims.

Authorised LawnMaster dealers are able to repair

and or replace parts that are defective within the limits of this warranty at no expense to the owner, and this includes the cost for replacement parts and or labour. Consumable items such as, but not limited to, oils, coolants, filters and spark plugs maybe an additional charge at the expense of the owner. All defective parts will be replaced and become the property of Steeffort.

Transportation costs related to freight and or delivery of replacement parts, and or whole goods maybe an additional charge at the expense of the owner.

## WARRANTY EXCLUSIONS

- Any damage which results from neglect of periodic maintenance specified by Steeffort.
- Any damage resulting from repair or maintenance by methods other than specified by Steeffort.
- Any product which has participated in a competition racing or rally event.
- Any damage which results from misuse and or use beyond the limitations of the intended purpose specified by Steeffort, such as overloading, and or under abnormal conditions.
- Any damage resulting from the use of non-genuine parts, lubricant or fluid not approved by Steeffort.
- Any damage resulting from modification or installation in other products in a way that is not approved by Steeffort that has an influence on the function and/or performance of the products.
- Any damage that results from operating under conditions that are not specified in the Owner's Manual either intentionally or by error.
- Fading of painted surfaces, deterioration of plated surfaces, deterioration of rubber and plastics including, rusting due to the passage of time.



- Normal phenomena such as noise, vibration and or oil, are considered by Steelfort as not affecting the quality, function or performance of the product.
- Any damage due to improper storage and or transport.
- Consumable replacement items: Spark plugs, contact points, shear pins, fuel strainers, oil filter elements, air cleaner elements, brake shoes or pads, clutch components, fuses, motor brushes, gaskets, tube or hoses, belts, cutting blades, light bulbs, serviceable bearings. Petroleum and others fluids: Oil, grease, battery electrolyte, and radiator coolant. Other items specified by Steelfort.
- Periodical maintenance items such as cleaning, inspection and adjustments.
- Any repair and/or adjustment performed by persons other than an authorised LawnMaster dealer, or damage resulting therefrom. All maintenance and repairs conducted by unauthorised LawnMaster service dealers and or persons will void the warranty.
- Any repair and/or adjustment to correct improperly and or poor-quality work that is previously performed.
- Incidental expenses that are incurred in the warranty claim for additional expenses such as towing, communications, accommodation and meals, that are incurred due to the breakdown of the product at a remote location are not covered.
- Any expense related to personal injury and/or property damage, (exclusive of the product itself). Compensation for loss of time, commercial losses or rental costs of a substitute product during the period of adjustment.
- Any damage which results from unavoidable natural disasters, fire, collision, theft, etc.
- Any normal wear or deterioration, such as that of sliding and or rotating parts caused under normal operating conditions i.e., normal wear to pistons, piston rings, cylinder bores, piston pins, valve seats, stems and bearings.
- Any damage resulting from exposure of the product to soot and smoke, medicines and chemical agents, seawater, sea breeze, salt or other environmental phenomena

**DOMESTIC USE:**

Personal, residential or household use only and is covered by a 3-year warranty. NOTE: These warranty conditions apply in New Zealand only.



**COMMERCIAL USE:**

All uses other than domestic use, including use for income-producing (including farming) or rental purposes have a 90-day warranty. NOTE: These warranty conditions apply in New Zealand only.

# LawnMaster®

## FIND US

 [www.lawnmaster.co.nz](http://www.lawnmaster.co.nz)

  [lawnmasternz](https://www.instagram.com/lawnmasternz)

---

### Steelfort

500 Rangitikei Street, Private Bag 11045  
Palmerston North, 4412, New Zealand  
06 350 1350

### Steelfort Auckland

880 Great South Road, Penrose  
Auckland, 1061, New Zealand  
09 573 1324