

LawnMaster®

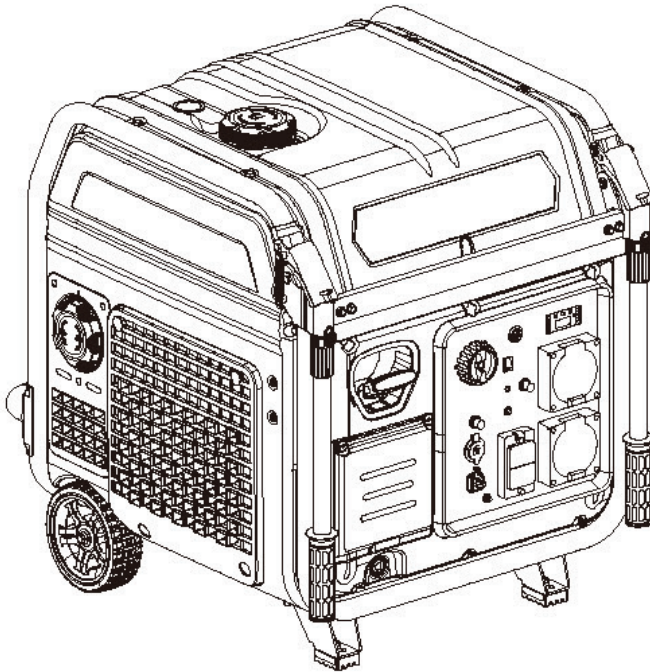

INVERTER GENERATOR

SAFETY AND OPERATING MANUAL

PLEASE READ THIS MANUAL CAREFULLY BEFORE OPERATING THE UNIT

LGBQH9200(E)



A STEELFORT PRODUCT



PROUDLY
NZ OWNED



TABLE OF CONTENTS

OPERATOR SAFETY	3
GETTING STARTED	4
Unpacking	
Assembly	
FEATURES & CONTROLS	7
Control Panel	
OPERATION	9
Operation Checklist	
Operation Conditions	
Engine Oil	
Engine Fuel	
Operation Place	
Grounding	
Battery Connection	
STARTING THE GENERATOR	12
Electric Start	
Wireless Remote Start	
Manual Start	
CONNECTING TO THE ELECTRICAL DEVICES	14
Loading Capacity	
Wattage Reference Chart	
STOPPING THE ENGINE	15
MAINTENANCE	15
Maintenance Schedule	
Generator & Engine Maintenance	
Air Filter	
Spark Plug	
Spark Killer	
STORAGE & TRANSPORT	19
TROUBLESHOOTING	20
SPECIFICATIONS & WIRING DIAGRAMS	22
WARRANTY	24

OPERATOR SAFETY

SAFETY RULES

This manual contains important safety information and instructions to operate the LawnMaster Inverter Generator.

PLEASE READ THIS MANUAL CAREFULLY BEFORE USING THE UNIT.

Failure to adhere to the safety instructions could result in property damage and/or serious personal injury.

This manual should be considered a permanent part of the generator and should remain with the unit at all times. All information in this publication is based on the latest product information available at the time of printing.

Product Information and specifications can be altered and/or improved without notice. Content from this publication may not be reproduced without written consent.

DANGER

Indicates a hazardous situation which, if not strictly complied with, will result in substantial property damage and or serious injury.

WARNING

Indicates a hazardous situation which, if not strictly complied with, may result in property damage

CAUTION

Indicates a hazardous situation which, if not strictly complied with, could result in property damage or personal injury.

The warnings and precautions discussed in this manual does not cover all possible conditions and or scenarios that may occur.

It must be understood by the operator that common sense and caution must be taken into consideration when operating this product, as these are factors which cannot be built into this manual.

WARNING

This generator is intended for domestic consumer use only. Damage and faults created from commercial use may void warranty. These generators are designed for full time operation. No personal modifications should be made to any part of the unit.

DANGER

TOXIC FUMES

- The exhaust of the engine contains carbon monoxide, an odorless, colorless poison gas. Using the engine in confined/indoor spaces can be extremely dangerous and life threatening.
- DO NOT use the generator inside and or in enclosed spaces EVEN IF doors and windows are open. Only use the engine in well ventilated areas and consider wind and airflow when positioning the engine.

KICKBACK

- Rapid retraction of the starter cord will pull hand and arm towards the engine faster than you can let go. Unintentional startup can result in serious injury.

FIRE

- When operating the unit, the engine may create sparks that could trigger fires.
- When operating around dry vegetation such as agricultural crops, forest, bush, grass, or other similar environments please be careful.
- This engine may not be equipped with a spark arresting muffler. In some countries and regions, a spark arrester is required by law. Please contact your local council and or fire agency for laws and regulations relating to fire prevention requirements.
- Petrol is highly flammable and explosive. A fire and or explosion from petrol can cause severe burns or result in serious personal injury including death.
- Keep flammable items away while handling petrol. Fill fuel tank outdoors and in a well ventilated area with the engine stopped.
- Always wipe spilled fuel and wait until the fuel has dried before starting the engine.
- DO NOT operate the engine with known leaks in the fuel system. Use proper fuel storage and handling procedures.
- DO NOT store fuel or other flammable materials near the generator.

- Empty the fuel tank before storing or transporting the generator. Keep fire extinguisher handy at all times.

BATTERY

- Lithium battery is maintenance free, if you have any question, please contact a local LawnMaster authorised dealer.

HOT SURFACE

- Running the generator will produce heat and severe burns may occur upon contact. DO NOT touch the engine while under operation or just after stopping the unit.
- Avoid contact with hot exhaust gases and or hot surfaces.
- Maintain at least 1m of clearance on all sides to ensure adequate cooling. Combustible material can catch fire upon contact. Maintain at least 3m of clearance from combustible materials.

MOVING PARTS

- Moving parts can cause severe injury. Keep hands and feet away from the unit.
- DO NOT operate engine with covers, shrouds, or guards removed.
- DO NOT wear loose-fitted clothing, dangling drawstrings or items that could become caught or entangled.
- Tie up long hair and remove jewelry. The moving parts may catch operator's hand, feet, hair and or loose clothing resulting in serious injury.

GENERAL WARNINGS

- Before use, check for loose or damaged parts, signs of oil or fuel leaks, and any other condition that may impact operation.
- Repair or replace all damaged and or defective parts immediately.
- Locate all operating controls and safety labels.
- Make sure all the safety instructions are in correct working condition.
- Operate only on level surfaces.
- DO NOT expose the generator to excessive moisture, dust, and or dirt.
- Keep all safety guards in place and in proper working order at all times.
- DO NOT allow any material to block the cooling slots.
- DO NOT allow children or untrained people to operate the unit.
- DO NOT leave the generator unattended when

it is in operation. Always turn off the generator prior to leaving the area.

ELECTRIC SHOCK

- The generator produces powerful voltage and the electricity and can be dangerous and cause serious life threatening injuries if an electric shock is received.
- Please ensure that the unit is properly connected to an appropriate ground to help prevent electric shocks.
- Failure to properly ground the unit can result in electrocution, especially if the generator is equipped with a wheel kit. Consult an electrician for local grounding requirements.
- Installation should be performed by a certified electrician. Improper Installation could result in serious injury.
- To reduce the risk of electric shocks. DO NOT use electrical cords that are worn, frayed, bare or otherwise damaged.
- DO NOT touch bare wires or receptacles.
- DO NOT operate the unit in wet weather.
- Keep the generator dry and DO NOT handle generator or electrical cords while standing in water, while barefoot, or while hands or feet are wet.
- Keep children or pets away.
- DO NOT plug the unit into a building electrical system without the proper use and installation of a transfer switch installed by a qualified electrician.
- When using the generator for backup power, notify your utility company.
- Use approved transfers to isolate generator from electric utility.
- Failure to isolate the unit from the power utility could result in serious injury to the staff and utility workers due to back-feed of electrical energy.

GETTING STARTED

1. UNPACKING

Remove the generator from the packaging

1. Place box on a solid and flat surface
2. Carefully cut each corner of the packaging box from top to bottom. Lay each side open and flat on the ground.
3. Remove all accessories except the generator from the packaging box.

2. ASSEMBLY

ASSEMBLE WHEELS

After fixing the wheel axle assembly on the frame, install the wheels and spacers on the wheel axle assembly in turn, and fix it with bolts.

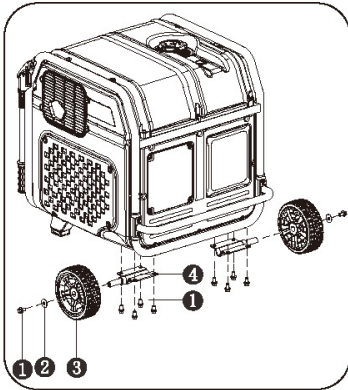

1. Bolt M8X14
2. Washer
3. Wheel
4. Wheel Axle Assembly

INSTALL SUPPORT FEET

Align the mounting holes of the support feet with the mounting holes of the rack, and fasten the support feet to the rack with bolts.

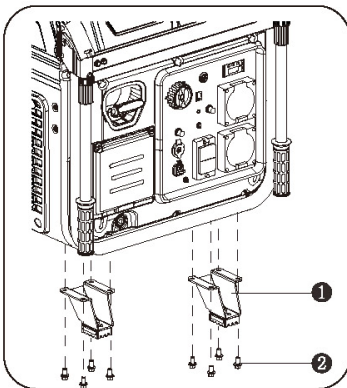

1. Support Feet Assembly
2. Bolt M6X16

ASSEMBLE REAR ARMREST

After aligning the rear armrest mounting holes with the generator mounting holes, fasten them with bolts.

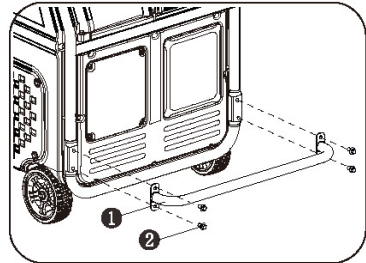

1. Rear Armrest
2. Bolt M8X14

INSTALL HANDLE

Align the handle and the nylon washer of the brake pin with the mounting hole of the push handle, and then install the washer and retaining ring after the pin is passed through. The installation steps of the handle rack are the same as above. After installation, hang the two ends of the brake spring on the handle rack and the handle respectively. The handle connecting bar is installed on the inner side of the handle and fixed with bolts.

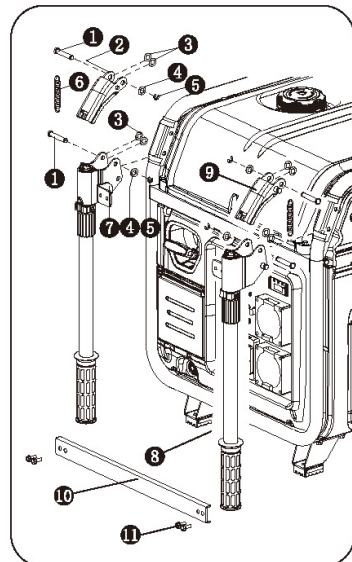

1. Pin 8X45
2. Bolt M8X14
3. Nylon washers
4. Washer
5. Retaining Ring
6. Spring
7. Handle Assembly (Left)
8. Handle Assembly (Right)
9. Armrest Rack (Right)
10. Handle Connecting Bar
11. Bolt M6X12

HANDLE OPERATION

The handle can be unfolded by directly lifting it up, and the handle has a self-locking function. After the handle is fully lifted, the position of the handle will be locked and will not fall freely.

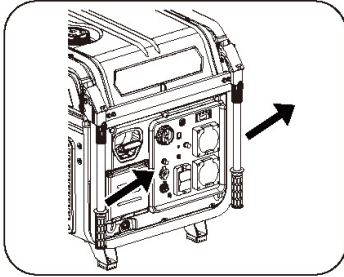

Before lowering the handle, lift it up slightly then turn the handle inward and press down to lower the handle.

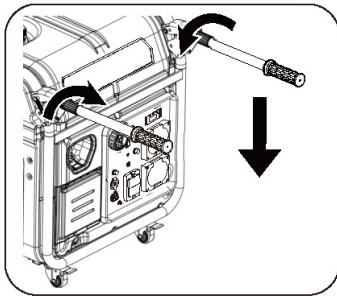

MOVING THE GENERATOR

WARNING

Failure to follow these instructions could result in personal injury or damage to the generator.

CAUTION

- ALWAYS turn the generator off and ensure the fuel valve is closed.
- ALWAYS make sure engine and muffler are cooled down before the generator can be handled safely (typically 15-30 minutes.)
- Do not drop or strike unit or place under heavy objects.

Lift unit up by the frame with 2 people and move to the desired location.

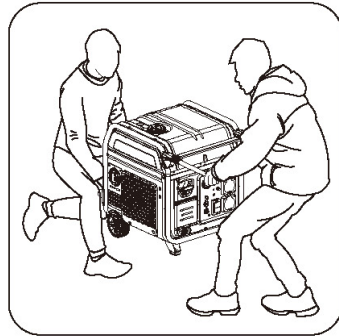

FEATURES & CONTROLS

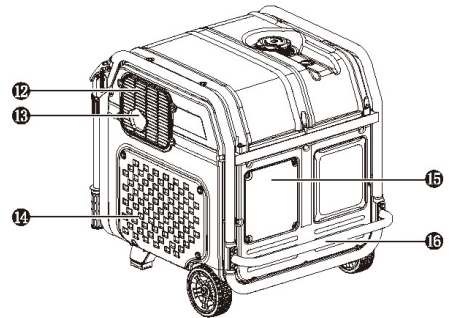
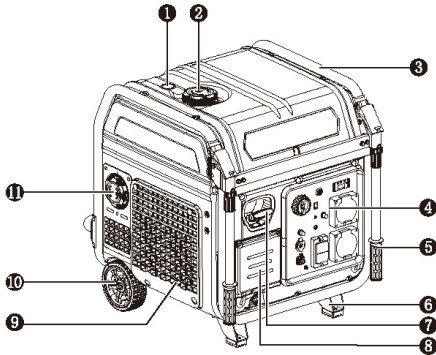

- | | | |
|---------------------------|-------------------------------------|---|
| 1. Lever Indicator | 6. Support Feet Assembly | 11. Air Filter Maintenance Cover |
| 2. Fuel Cap | 7. Recoil Starter | 12. Muffler Blind Window |
| 3. Rack | 8. Battery Maintenance Cover | 13. Muffler |
| 4. Control Panel | 9. Engine Inlet Shutter | 14. Oil Drain Cover |
| 5. Push Handle | 10. Wheel | 15. Oil Maintenance Cover |
| | | 16. Rear Armrest |

CONTROL PANEL

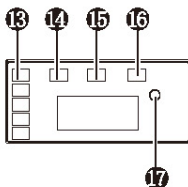
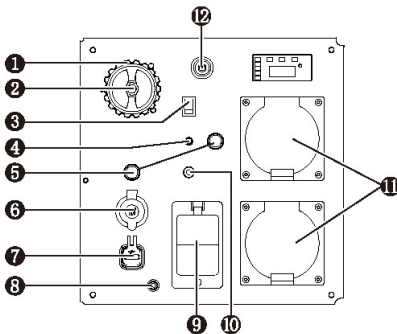

- | |
|-------------------------------------|
| 1. Start/Stop Switch (Outer) |
| 2. Fuel Switch (Inner) |
| 3. Energy-Saving Switch |
| 4. Learning Button |
| 5. Breaker |
| 6. 12V DC |
| 7. USB |
| 8. Ground Terminal |
| 9. RCD |
| 10. Charge Port |
| 11. Output Receptacle |
| 12. Engine Switch |
| 13. Power Indicator |
| 14. Overload Indicator |
| 15. Running Indicator |
| 16. Low Oil Light |
| 17. Reset Buton |

**FUEL SWITCH (INNER)
START STOP SWITCH (OUTER)**

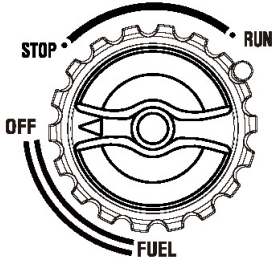

Fuel Switch: Fuel ON/OFF
Start/Stop Switch: STOP/RUN

OVERLOAD INDICATOR (RED)

The overload indicator light is on, indicating that the generator has detected the output of the connected electrical equipment has exceeded the load capacity of the generator. At this time, stop the generator to protect the generator and the electrical equipment connected. The running indicator (green) goes out, the overload indicator (red) flashes for 3 seconds/ time, but the generator will not stop running.

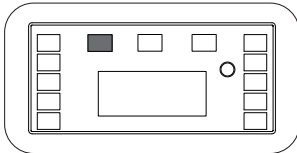

When the generating set has no output and the overload indicator is on, please take the following steps:

1. Lower the total load of the connected electric devices to the rated output range of the generator.
2. Check the air filter to ensure it is not clogged and the generator is in an open area to allow enough air flow to the generator.
3. Press the reset button.

RUNNING INDICATOR (GREEN)

The running indicator lights up when generating set starts and has normal output.

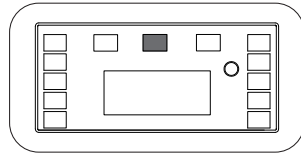

OIL ALARM LAMP (YELLOW)

When the oil level drops below the lower limit, the oil protection system will stop the engine automatically and oil alarming lamp will blink when recoil starter is pulled. The engine will not run until the oil has been filled to the proper level.

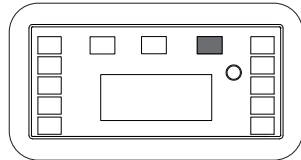

Note: If the generator fails to start when the engine is turned off, please turn the start-stop knob to the "RUN" position, and then pull the starter handle. If the oil alarm indicator lights up, it means that the oil capacity is insufficient, please add oil and restart.

RESET BUTTON

The reset button is used to restore output if an overload occurs. To restore output, reduce the load(s) and press the reset button.

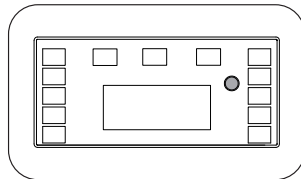

ENERGY-SAVING SWITCH

When the electrical equipment needs a large starting current, please put the energy-saving switch in the "OFF" position.

While when the electrical equipment needs a small starting current, please put the energy-saving switch in the "ON" position.

Note: Please set the energy-saving switch to "OFF" position when connect to an air compressor, pumps, circular saws etc., Due to large starting current required.

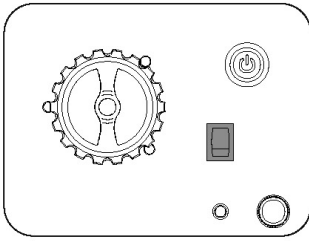

GROUNDING TERMINAL

The grounding terminal is designed to prevent electric shock by connecting it to the grounding wire. The generating set must be properly grounded before operation.

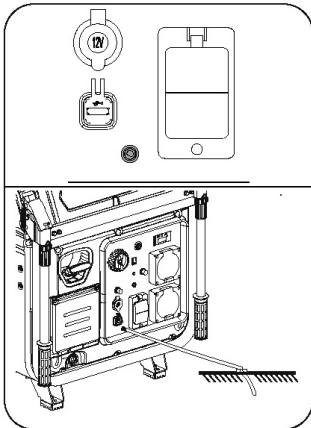

OVERLOAD PROTECTOR

When generator is overloaded or overheated for a long time, the over-current protector will protect the output. If it is protected, please lower the load or run without load for a few minutes, and then press the button of the over-current protector to restore the output.

Note: Similar to the circuit breaker, flip the switch upward to restore the output. The over-current protector/circuit breaker will be affected by factors such as operating current and ambient temperature, so there will be differences in the protection time.

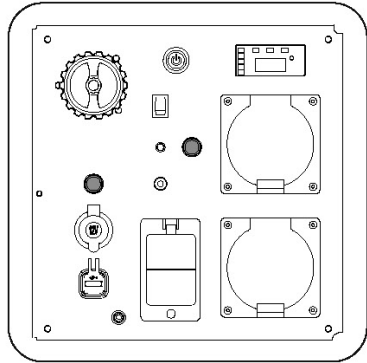

IV. OPERATION

1. OPERATING CHECKLIST

OPERATING LOCATION

Only use this generator OUTSIDE and in well ventilated areas.

Only operate the generator on a flat, level surface and in a clean, dry operating environments. Only use the generator for applications within its operating scope. If you have any question regarding applicable scope, please speak to your nearest Service Agent.

In some locations and regions, the generator may require additional provisions and or regulations for operation, please consult with your nearest Service Agent.

ANGER

TOXIC FUMES

The exhaust of the generator contains carbon monoxide, using the engine indoors may cause serious personal injury including death. DO NOT use the generator inside any buildings or within enclosed spaces EVEN IF doors and windows are open. Place the generator in a well-ventilated and clean area. Note the wind direction and airflow when placing the generator.

HIGH ALTITUDE

This generator may require a high altitude carburetor kit to ensure correct operation at high altitudes. Consult with your local authorised LawnMaster dealer for high altitude kit information if you intend to operate the generator at altitudes above 5,000 feet (1,500 meters).

CAUTION

- Even with carburetor modification, generator horsepower will decrease by 3.5% for every 1,000 feet (300 meters) increase in altitude. The effect of altitude on horsepower will be greater than this if no carburetor modification is made.
- Operating the engine at altitudes below 5,000 feet (1,500 meters) with a modified carburetor may cause the generator to overheat and result in serious engine damage. Please restore factory specifications of the carburetor with your service dealer when using the engine in low altitude areas.

2. OPERATING CONDITION

Check for loose or damaged parts, signs of oil or fuel leaks, and any other condition that may affect proper operation. Repair and or replace with genuine spare parts immediately.

WARNING

- Failure to correct problem(s) before operation may result in property damage and or serious personal injury.
- Remove excessive dirt or debris, especially around the muffler and recoil starter.
- DO NOT move or tip the generator during operation.

3. ENGINE OIL

- Place the engine on a level surface with engine stopped. Check the engine oil level.
- Remove the oil maintenance cover.

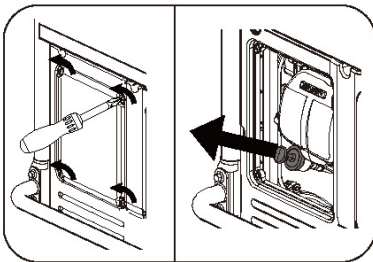

- Place the dipstick in the filler neck and stay at the neck of the filler neck.
- Remove the dipstick again and check oil level. Level should be between the upper and lower limit.
- Fill to the upper limit of the dipstick with the recommended oil if the oil level is too low.

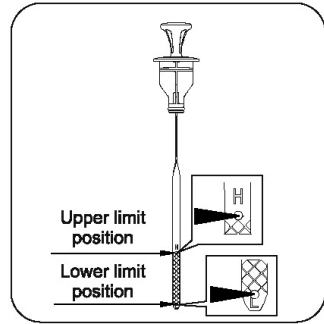

Reinstall and fully tighten the dipstick. Refer to add oil instruction in MAINTENANCE section for more information.

Oil level: 1.1 L

Recommended grade of engine oil: SAE10W-30

WARNING

- Oil is a major factor affecting performance and service life.
- We recommend using LawnMaster 4-Stroke 10W30 Oil (PP01020005). You can find more information about this in the MAINTENANCE section of this manual.
- **OIL MUST BE PLACED IN ENGINE BEFORE STARTING.** This engine is not filled with oil at the factory. Any attempt to crank or start the engine before it has been properly filled with the recommended type and amount of oil may result in engine damage and void your warranty.

CAUTION

Operate generator only on level surfaces. The engine is equipped with a low oil sensors (if applicable) that will automatically stop the engine when the oil level falls below safe threshold. To avoid the inconvenient unexpected shutdowns, fill to the upper limit and check oil levels regularly.

4. ENGINE FUEL

- With the engine stopped, check the fuel level gauge. Refill the fuel tank if necessary.
- Use clean, fresh, regular unleaded petrol.
- DO NOT mix oil with petrol.
- Always wipe up any spilled fuel.
- Be sure not to fill above the upper limit mark
- Always allow room for fuel expansion.
- Place the dipstick in the filler neck and stay at the neck of the filler neck.

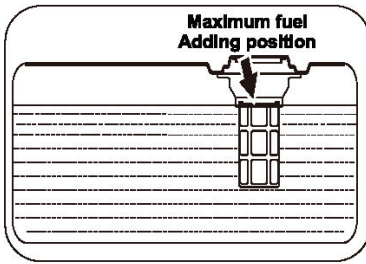

- DO NOT use engine and or carburetor cleaning products in the fuel tank as this could result in permanent damage.
- It is important to prevent gum deposits from forming in essential fuel system components, such as the carburetor, fuel filter, fuel hose or tank during longterm storage. Also, experience indicates that alcohol-blended fuels (gasohol, ethanol or methanol) can attract moisture, which could lead to separation and formation of acids during longterm storage.
- Acidic fuels can damage the fuel system while in storage. Be sure to review the instructions in the "Storage" section.
- Petrol/Alcohol Blends: up to 10% alcohol, 90% unleaded petrol by volume is approved as a fuel. Other forms of petrol/alcohol blends are not approved.
- Damage and faults caused by old, stale or contaminated fuel may void warranty.

DANGER

- Do not fill the fuel tank above the upper limit. Over filling will result in engine damage and may void warranty.
- Petrol is highly flammable and extremely explosive. Keep flammable items away while handling petrol as this could result in a fire.
- Fill fuel tank outdoors and well-ventilated areas with the generator stopped.
- Always wipe off spilled fuel and wait until the fuel has dried before starting the generator.

CAUTION

- To minimise gum deposits in your fuel system and to insure easy starting, do not use petrol that is left over from the previous seasons.
- Pressure can build up in the fuel tank. Allow the generator to cool for at least two minutes before removing fuel cap. Loosen the fuel cap slowly to relieve any pressure in the tank.

4. GROUNDING

The generating set must be properly connected to an appropriate ground. It helps prevent electrical shock if a ground fault condition exists in the generating set or in connected electrical devices, especially when the unit is equipped with a wheel kit. Proper grounding also helps dissipate static electricity, which often builds up in ungrounded devices.

DANGER

ELECTRICAL SHOCK

Failure to properly ground the generator could result in electric shocks.

A ground terminal has been provided on the generating set. For remote grounding, connect a length of heavy gauge (4mm²) copper wire between the generating set ground terminal and a copper rod driven into the ground.

5. BATTERY CONNECTION

Remove the fixing bolts and the battery maintenance cover, loosen the battery rubber belt, connect the battery terminals to the motor terminals, and then install the battery maintenance cover.

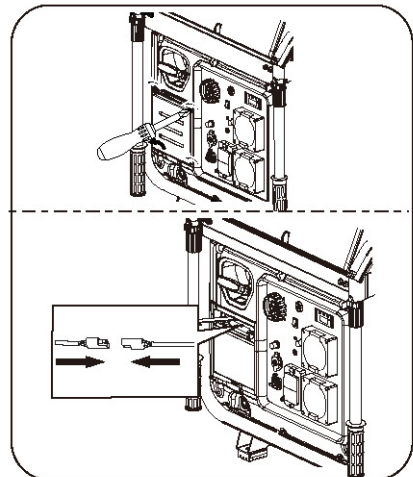

Disconnect all electrical devices from the generator and switch off the AC circuit breaker before start the engine. The generator may be hard to start with electrical devices. The power draw of the connected electrical equipment cannot exceed the maximum

capacity of the generator, please refer to the specification table for details.

STARTING THE GENERATOR

WARNING

When the generator is idle for a long time or improper use or other factors, the battery is undercharging so that the generator cannot be electrically started, follow the manual start steps to control the choke and start the generator manually. The generator will automatically charge the battery during operation.

1. Perform Operating checklist and remove all loads.
2. Turn the fuel switch to "FUEL" position.

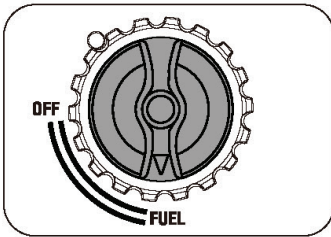

3. Turn the start/stop switch to "RUN" position

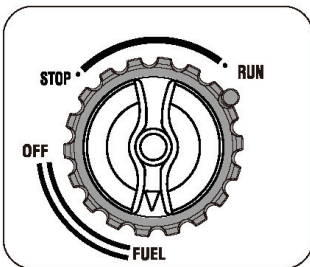

4. Select according to the actual configuration of the user.

ELECTRIC STARTING

1. Press the engine switch button to enter standby mode



2. Press the engine switch button to start the engine.

WARNING

If it fails to start, the generator will restart by itself. If it fails to start after repeated 6 times, please allow the generator to cool for 1 minute and start again. Sometimes the generator can take a few attempts to start in cold weather. If machine does not start in the first 10 seconds, wait for 30 seconds before attempting again. If the motor turns a little then stops when you press the Start key, it may indicate a low battery. Charge the battery before operation or start by recoil start.

CAUTION

During the operation of the unit, the battery supplies power for the solenoid valve of the carburetor. For this, when the unit is turned off, make sure that the starting switch is in "STOP" position and otherwise the storage battery voltage is reduced due to the operating solenoid valve of the carburetor, impacting on starting for next time.

If engine is equipped with an engine oil alarm, it is possible to prevent engine start when the engine oil in the crankcase is lower than the minimum level.

During running-in, routinely inspect the engine oil. See maintenance section for recommended maintenance period.

WIRELESS REMOTE START

1. Press the engine switch button to enter standby mode. If generator was turned off using the remote key fob within the last 24 hours, it will already be in standby mode.

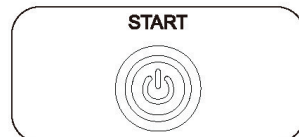

2. Press and hold the "ON" key for 1 second and release it to start the generator.

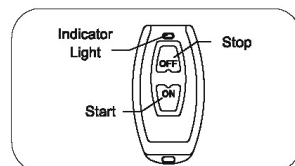

WARNING

Remote transmitter and generator learning
The generator and the remote controller have been successfully matched at the factory, and users do not need to perform matching when use.

MATCHING WIRELESS REMOTE CONTROL (IF APPLICABLE)

1. Turn the Start/Stop switch to "RUN" position
2. Press and hold the learning button until a blue light comes on and then release, the blue light stays on.
3. Press and hold the "OFF" button of the remote control until the learning lamp flashes 1 time and then release it.
4. Press and hold the "ON" button of the remote control until the learning lamp flashes for 1 time and then release.
5. Press and hold the learning button until it goes out and then release it.

MANUAL START

When starting engine, grasp the recoil starter handle and pull slowly until resistance is felt. Then pull rapidly to avoid kickback.

WARNING

Check starter cord conditions before operating. Have it replaced immediately by your local service dealer if cord is frayed.

KICKBACK

Rapid retraction of the starter cord will pull hand and arm towards the engine faster than you can let go.

Unintentional startup can result in entanglement, traumatic amputation or laceration. Broken bones, fractures, bruises or sprains could result.

When the battery power of the generator is too low to start, please operate the choke handle as the following figure to start the generator.

CAUTION

Choke plate should be setting in different width due to temperature and other factors.

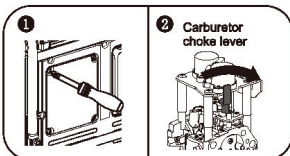

1. Remove the oil maintenance cover.
2. Move the carburetor choke lever to the right to close the choke.
3. When starting the engine, grasp the recoil starter handle and pull slowly until resistance is felt. Then pull rapidly to avoid kickback.

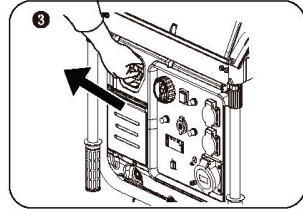

4. After the generator has started, move the carburetor choke lever to the left to open the choke.

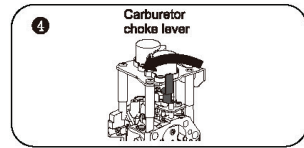

After completing the above operations, the generator can be connected to electrical equipment.

CAUTION

Do not restart the generator without removing the fault. It is strictly forbidden to start the generator after using other batteries without authorization.

WARNING

It is prohibited to start or close the generating set when the output terminal of generating set is connected to an electric device and the electric device is in "ON" state.

CONNECT TO ELECTRICAL DEVICES

Inspect power cord for damage before using. A hazard is electrical shocks from crushing, cutting or heat damage.

1. Confirm that the generator is grounded. If the electric device requires grounding, the generator must be grounded.
2. Ensure that all electrical devices are turned off.
3. After the generator is started, let it run for a few minutes to allow it to warm up to a steady state.
4. Confirm the connection and then turn on the electric device you expected.
5. Before stopping the generator, please turn off the electrical device or disconnect the output.
6. If the generator provides power to more than one electrical devices, start each electrical device according to the size of the load, from small to large.

DANGER

If connected devices overheat, turn them off and disconnect them from generating set.

ELECTRICAL SHOCK

- To reduce the risk of electrical shock, DO NOT use electrical cords that are worn, frayed, bare or otherwise damaged.
- DO NOT touch bare wires or receptacles.
- DO NOT handle generator or electrical cords while standing in water, while barefoot, or while hands or feet are wet.

LOADING CAPACITY

You must make sure your generator can supply enough rated (running) and surge (starting) watts for the electrical devices you plan to power at the same time. Follow these simple steps to calculate the running and starting watts that are necessary for your purposes.

WARNING

- DO NOT overload the generator.
- Exceeding the generator's capacity can damage the generator and/or electrical devices connected to it. Faults and damaged caused by overloading may void warranty.

1. Select the electrical devices you will power at the same time.
2. The amount of power you need to run all the devices is the total rated (running) watts of these items.
3. Identify how many surge (starting) watts you will need. Surge wattage is the short burst of power needed to start electric power tools and or appliances. Because not all motors start at the same time, total surge watts can be estimated by adding only the electrical device(s) with the highest additional surge watts to the total rated watts from step 2.

WATTAGE REFERENCE CHART

Electric equipment		Rate power(W)	Starting power(W)
Appliances	Tablet TV 27"	80	100
	Energy saving lamp	5-50	5-50
	Electric cooker	1000	1000
	Computer	250	250
	Electric fan	50	100
	Washing machine	250	500
	Refrigerator	50	300
	Air-conditioner	1600	3200
Electric tooling	Electric hammer	1000	1500
	Impact Hammer	3000	6000
	Water pump	2200	5000
	Electric welding machine	5000	7500
	Air compressor	5000	10000

WARNING

It is necessary to equip with circuit protector or switch to isolate the generating set from the electric utility when the generating set is mainly used for backup. Failure to isolate the generating set from the power utility may result in injury or death to electric utility workers and damage to the generating set due to back feed of electrical energy.

STOPPING THE ENGINE

Turn off the electrical devices and then unplug all the electrical device plugs from the panel.

WARNING

NEVER stop the engine with electrical devices connected and with the connected devices turned "ON".

1. Press the "OFF" button on the remote.

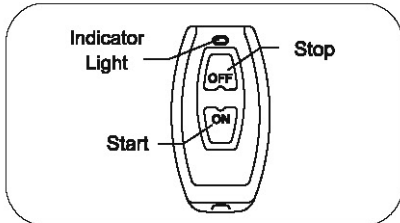

2. Turn the fuel switch to "OFF" position.

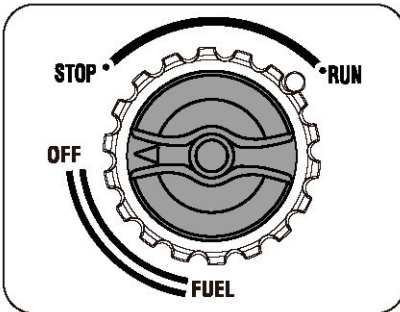

WARNING

Generator Long-Term Storage:

If the generator needs to be stored for a long period of time, please turn the fuel switch to the "OFF" Position. After the fuel in the carburetor fuel cap is burnt out and the generator automatically stops, turn the start-stop knob to the "STOP" position.

If the start-stop switch knob is not placed in the "STOP" position, the battery will be depleted of power, making it impossible to start the generator normally.

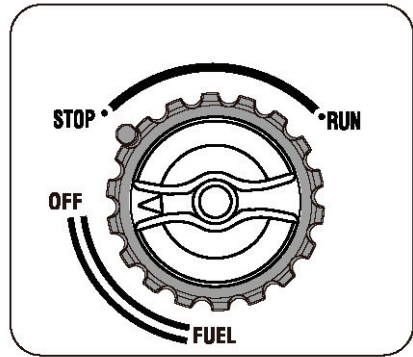

MAINTENANCE

It is the operator's responsibility to complete all scheduled maintenance and or servicing in a timely manner. Always correct any issues before operating the generator. Follow all inspection and maintenance recommendations that are listed in the manual.

WARNING

Improper maintenance and or failure to correct problems prior to operating the unit may cause the unit to malfunction and result in property damage and or serious personal injury. Improper maintenance and servicing may void warranty.

DANGER

Accidental starts can cause serious personal injury. Remove and ground the spark plug wire before performing any service.

CAUTION

The filter element may contain PAHs, PAHs that is harmful for your health. Please wear gloves for protection during air filter maintenance.

1. MAINTENANCE SCHEDULE

Before servicing the generator, stop the generator, disconnect all electric devices and battery (if equipped) and allow the generator to cool down.

below. Service your generator more frequently when operating in adverse conditions. Contact your local LawnMaster Service Dealer if the generator requires maintenance.

Follow the service intervals indicated in the chart

		Each time before use	The first month or 10 hours <small>note2</small>	Every three months or 50 hours <small>note2</small>	Every six months or 100 hours <small>note2</small>	Every year or 300 hours <small>note2</small>
Engine oil	Inspection	√				
	Replacement		√		√	
Air filter	Inspection	√				
	Cleaning				√ <small>note3</small>	
Spark plug	Inspection and adjustment				√	
	Replacement					√
Spark Extinguisher <small>note1</small>	Cleaning				√	
Idle speed	Inspection and adjustment					√ <small>note4</small>
Valve clearance	Inspection and adjustment					√ <small>note4</small>
Carbon canister <small>note1</small>	Inspection	Every two years <small>note4</small>				
Low permeability oil tube <small>note1</small>	Inspection	Every two years <small>note4</small>				
Oil tube	Inspection	Every two years <small>note4</small>				

Note 1: Applicable types (if available).

Note 2: Before each season and after (whichever comes first).

Note 3: Service more frequently under severe, dusty, dirty conditions.

Note 4: To be performed by knowledgeable and or experienced owners. However, we recommend using an authorised service agent to conduct all maintenance and servicing need for the purpose of voiding issues with warranty.

2. GENERATOR MAINTENANCE

- Make certain that the generator is kept clean and stored properly.
- Use a damp cloth to clean exterior surfaces of the generator.
- Use an compressed air (25 PSI) to clear dirt and debris from the generator.
- Inspect all air vents and cooling slots to ensure that they are clean and unobstructed.

WARNING

- DO NOT use water to clean the generator. Water can enter the generator through the cooling slots and damage the generator windings.
- DO NOT modify the generator in any way.
- DO NOT tamper with governed speed. Generator supplies correct rated frequency and voltage when running at factory set.
- Tampering with the factory reset governor will void your warranty

3. ENGINE MAINTENANCE

3.1 ENGINE OIL

LawnMaster 10W30 Oil (PP01020005) is recommended. Other viscosities shown in the chart may be used when the average temperature in your area is within the indicated range. **OIL MUST BE PLACED IN ENGINE BEFORE STARTING.**

Recommended Engine Oil Type

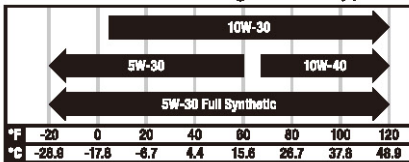

Ambient temperature
Oil capacity (rated):
See Parameters.

3.2 ADDING OIL

WARNING

The engine is not filled with oil at the factory. Any operation before it has been properly filled with the recommended type and amount of oil may result in engine damage and void your warranty.

1. Place the engine on a level surface.
2. Remove the oil maintenance cover and oil dipstick and wipe oil dipstick clean.

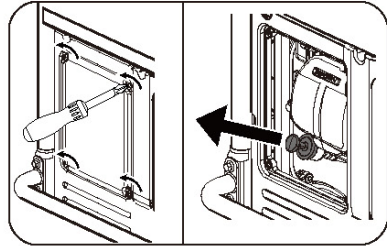

3. Add recommended oil to the upper limit.

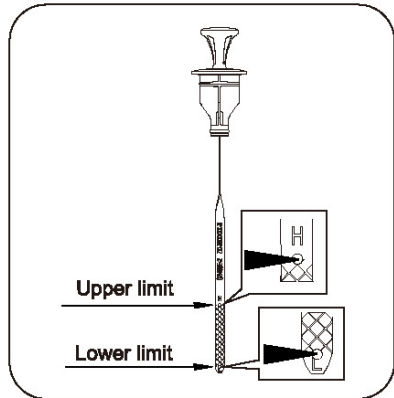

CAUTION

Oil level check

Insert the dipstick into filler port and stay at the filler neck. Do not screw the dipstick into the port, then remove the dipstick and check the oil level.

4. Insert the dipstick into its seal position and fix the oil maintenance cover.
5. Properly dispose of any used oil at an approved waste management facility.

3.3 CHANGING OIL

CAUTION

Change the oil when in hot engine state. The oil can reach up to 140 °C under that condition. Careful operation should be taken to prevent burns.

1. Place the machine on a level surface which is 300mm higher than the ground.
2. Remove the oil drain cover.

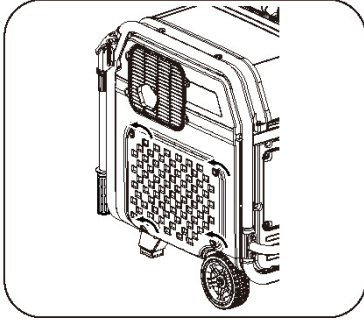

3. Place the oil container box under the oil drain hole of the generator and remove the drain bolt to drain out all the used oil.

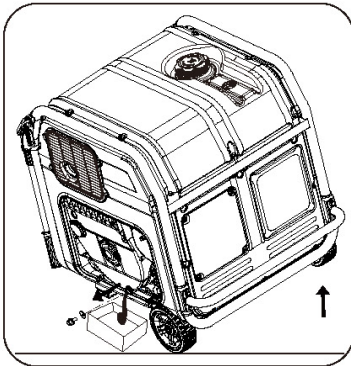

4. Fully tighten the drain plug, fix the oil drain cover.
5. Remove the oil maintenance cover.

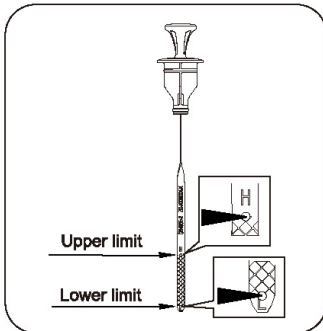

6. Fully insert the dipstick into the oil filling hole and reinstall the oil maintenance cover.
7. Properly dispose of any used oil at an approved waste management facility.

WARNING

The engine is not filled with oil at the factory. Any operation before it has been properly filled with the recommended type and amount of oil may result in engine damage and void your warranty.

4. AIR FILTER

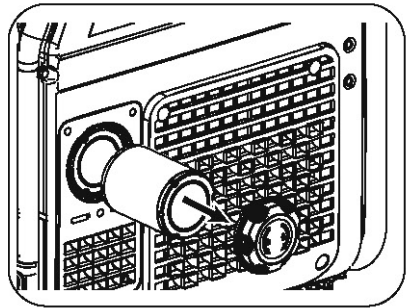

1. Unscrew the air filter maintenance cover.
2. Take out the air filter element.
3. Check whether the paper filter element is damaged, if damaged, please replace it in time.
4. Gently tap the filter element to remove the dust or debris attached to the filter element.
5. Put the filter element back into the assembly and screw it tightly with the air filter maintenance cover.

WARNING

The air filter is a key part that affects the emission performance, and any form of modification is strictly prohibited. It is prohibited to use the engine without installing or correctly installing the air filter, otherwise the engine will be seriously worn or damaged, and the product warranty will be void. It is strictly forbidden to use organic solvent to clean the paper filter element, and to use compressed air to blow and clean it.

5. SPARK PLUG

WARNING

Before repairing the spark plug make sure that the engine has cooled down completely.

1. Remove the oil maintenance cover after unscrewing the fixing bolt.
2. Clean any dirt from the spark plug cap and spark plug base.
3. Remove the spark plug cap.
4. Using socket wrench to loose and remove the spark plug.
5. Observe whether the spark plug and spark plug gasket are damaged, if necessary, replace them.
6. Check spark plug gap. If necessary, carefully bend one end of the electrode to adjust the clearance.

SPARK PLUG GAP: 0.6MM - 0.8MM

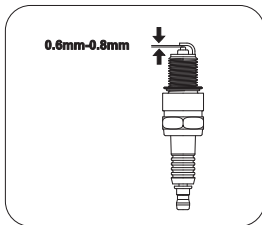

7. Carefully thread the plug into the engine by hand.
8. After the spark plug is seated, use spark plug wrench to tighten the plug.

SPARK PLUG TIGHTEN TORQUE: 20-25 N.M

9. Attach the spark cap to the plug and connect the spark plug wire to the plug.

WARNING

Only use the recommended spark plug or equivalent. DO NOT use spark plugs that have improper heat range.

10. Install Oil maintenance cover.

SPARK KILLER

(IF APPLICABLE)

1. Allow the generating set to cool completely before servicing the spark arrester.
2. Remove the muffler blind window first.
3. Remove the spark arrester screen.
4. Carefully remove the carbon deposits from the spark arrester screen with a wire brush.
5. Replace the spark arrester if it is damaged.
6. Reinstall the spark arrester in the muffler and reinstall the muffler blind window.

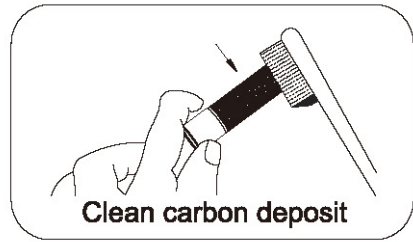

SPEED

The speed has been pre-set at the factory and should rarely require readjustment. Consult your local authorized LawnMaster dealer for such needs.

WARNING

Unapproved adjustment will damage your engine and/or your electrical devices and void your warranty.

ADJUSTMENT

There has no other service and/or adjustment need for your generator. Unapproved adjustments or tampering can damage your generator and your electrical devices and will void your warranty. Contact your local dealer for such needs.

WARNING

Tampering with the factory set governor will damage your generator and void your warranty.

STORAGE & TRANSPORTATION

STORAGE

The generating set should be started at least once every 2 weeks and allowed to run for at least 20 minutes. Follow the instructions below for longer term storage if the generating set will be out of service for 2 months or more.

WARNING

FIRE OR EXPLOSION

Gasoline is highly flammable and extremely explosive. Empty the fuel tank and shut off fuel valve before storing or transporting this generating set.

1. Allow the generating set to cool completely before storage.
2. Clean the generating set according to instructions in Maintenance section.
3. Drain all fuel completely from the fuel tank, fuel hose and carburetor to prevent gum from forming.
4. Turn the combination switch in "OFF" position to cut off the fuel.
5. Remove the oil drain plug to drain out the oil
6. Remove the spark plug and pour about 15 ml of fresh oil into the cylinder. Pull the recoil starter slightly to distribute the oil and lubricate the cylinder. And then attach the spark plug.
7. Store the unit in a clean, dry area out of direct sunlight.
8. Disconnect the battery.

TRANSPORTATION

When generator is being transported or put into short term storage, the generator should be in the normal operating position and fixed vertically to prevent fuel leakage. The combination switch should be in the "stop" position and knob of the fuel cap should be turned to the "OFF" position.

WARNING

When transporting do not overfill the tank. Do not operate the generating set while it is on vehicle. Take the generating set off the vehicle and use it in a well-ventilated place. Avoid a place exposed to direct sunlight when putting the generating set on a vehicle. If the generating set is left in an enclosed vehicle for many hours, high temperature inside the vehicle could cause fuel to vaporize resulting in a possible explosion. Do not drive on a rough road for an extended period with the generating set on board. If you must transport the generating set on a rough road, drain the fuel beforehand.

TROUBLE SHOOTING

Description of flashing mode of controller status light		
Flashing mode	Flashing mode state	Status
Green light always on	Proper functioning	With output
Green light always on, red light flashing	Overload	With output
Green light off, red light flashes once, and then flashes once every 3 seconds	Overload protection	Without output
Green light off, red light flashes twice, and then flashes twice every 3 seconds	Output short-circuited	Without output
Green light off, red light flashes three times, and then flashes three times every 3 seconds	Inverter overheat	Without output
Green light off, red light flashes four times, and then flashes four times every 3 seconds	Low engine speed	Without output
Green light off, red light always on	Insufficient engine power or other failures	Without output
<p>NOTES: The controller fault flashing lights and solutions in the above table can be found in the "Fault View" of the WeChat applet. Other fault flashing lights and solutions not seen in the above table can also be found in the "Fault View" of the WeChat applet. You can also contact Zonsen after-sales service personnel for troubleshooting.</p>		

Failure	Trouble	Solution
Generating set fails to start	start/stop switch is in "STOP" or fuel switch is in "OFF" .	Turn start/stop switch to "RUN" , and follow starting procedure to start the generating set . Turn fuel switch to "FUEL" , and follow starting procedure to start the generating set .
	Lack of fuel.	Fill fuel tank per instructions in this manual.
	Lack of engine oil.	Check oil level. This engine is equipped with a low oil sensor. The engine cannot be started unless the oil level is above the prescribed lower limit.
	No ignition.	Remove the spark plug cap. Clean any dirt around the plug base, and then remove the spark plug. Install the spark plug in the plug cap. Turn the start/stop switch to "RUN" position. Grounding the electrode to any engine ground, pull the recoil starter to see if sparks jump across the gap. If there is no spark, replace the plug. Reinstall the plug and start engine according to instructions in this manual. Consult Customer Service if necessary.
	Spark plug is splashed by fuel	Remove the spark plug and wipe the fuel.
	Battery undercharge (electric start)	Charge the battery by starting the generator manually (at least 30 minutes).
Generating set has no output	Breaker trip	Reset circuit breakers.
	Inadequate cord sets or extension cords.	Check cord sets or extension cords capabilities in section controls. Consult Customer Service if necessary.

SPECIFICATIONS & WIRING DIAGRAMS

1. SPECIFICATION (PARAMETER TABLE)

Feature		Model	BQH9000E	
Engine parameter	Engine model	GB460BE-2		
	Style	OHV, forced cooling, four stroke, single cylinder		
	Displacement (cm ³)	459		
	Ignition system	TCI		
	Start style	Hand recoil or electric starting		
	Oil capacity(L)	1.1		
Series parameter	Frequency(Hz)	50	60	
	Voltage(V)	110,220,230,110/220,115/230, 120/220,120/240		
	Rated power(kW)	7.2	7.2	
	Maximum power(kW)	7.5	7.5	
	Power factor	1		
	Insulation rate	F		
	Fuel capacity(L)	23		
	Operating temperature(°C)	-10~40		
	Max. site altitude of installation(m)	1500		
	Measured sound pressure level(dB(A))	≤75		
	Measurement uncertainty(dB(A))	≤1.5		
	Guaranteed sound power level(dB(A))	≤96		
	Net weight(kg) (With wheel & handle & rear armrest)	87		

Note: The generating set with different specification and configurations may have different parameters and may change at any time without notice.

2. WIRING DIAGRAMS

BQH9000E ELECTRIC START

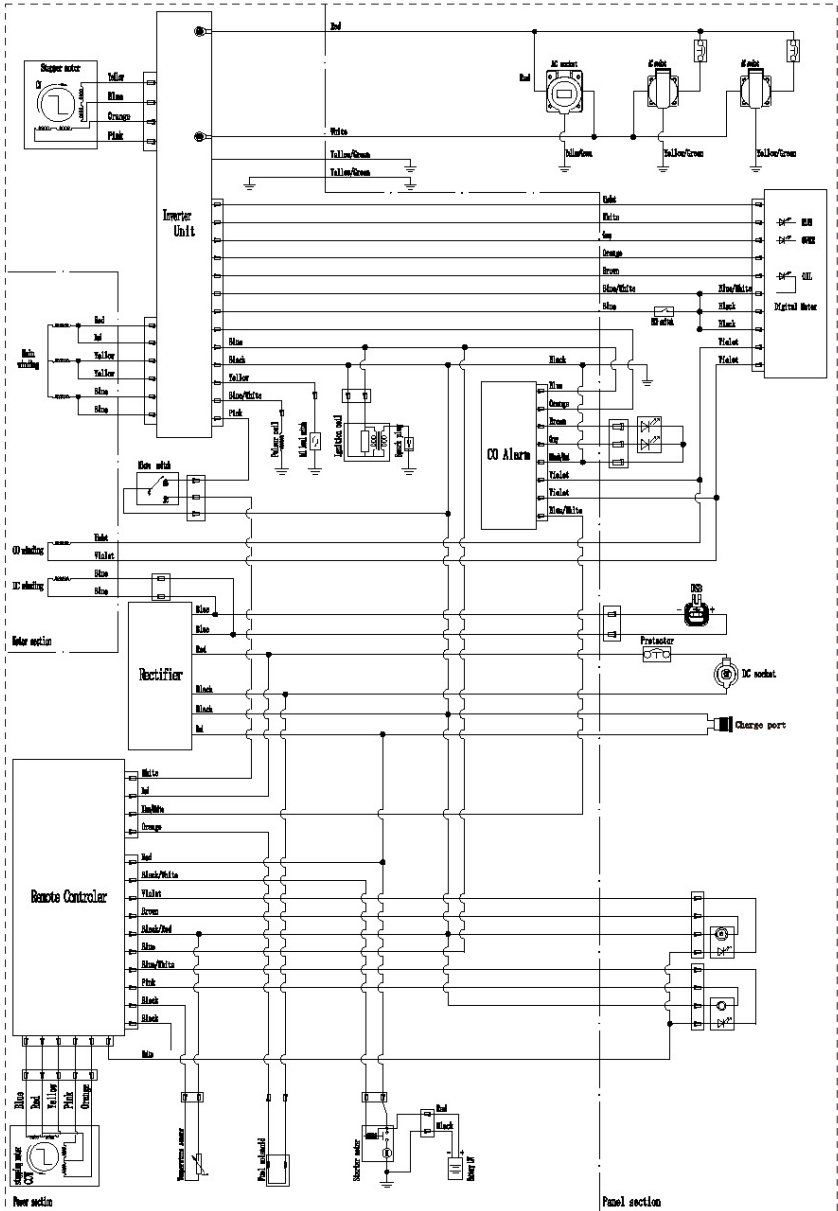

Note: Because of the difference of generator, the wiring diagram is only for reference.

XII. WARRANTY

3-YEAR DOMESTIC CONDITIONAL WARRANTY

UP TO 90 DAYS FOR COMMERCIAL USE.

LawnMaster Dealer extended warranty period for items that are:

- Registered at the time of sale.
- Serviced by an Authorised LawnMaster Service Dealer in accordance with the service schedule using Genuine parts and oils (proof required).
- Meeting all other warranty requirements.

LAWNMASTER LIMITED WARRANTY

The warranty applies to all new LawnMaster products that are identified by their unit serial number.

In order to be eligible for the LawnMaster limited warranty, you must have, maintenance performed according to the schedule contained in the relevant owner's manual that is supplied with the product, and ongoing maintenance performed by an authorised LawnMaster dealer.

Steeffort will recognise your statutory rights under the Consumers Guarantee Act 1993. To ensure the safe operation of this product, we strongly recommend that you only use an authorised LawnMaster dealer for all maintenance and servicing requirements. Authorised LawnMaster Dealers have access to special tools, training, and genuine parts that are required to maintain your LawnMaster product for peak operating conditions. The purchaser must keep an accurate record of all service and maintenance. This may be requested when assessing any future warranty claims.

To qualify for the LawnMaster extended Warranty, a warranty registration must be completed online through the Steeffort website (www.steeffort.co.nz) within ten (10) days following the date of purchase.

Proof of purchase documentation are required and must include the engine serial number and frame serial number as appropriate for all warranty claims.

Authorised LawnMaster dealers are able to repair

and or replace parts that are defective within the limits of this warranty at no expense to the owner, and this includes the cost for replacement parts and or labour. Consumable items such as, but not limited to, oils, coolants, filters and spark plugs maybe an additional charge at the expense of the owner. All defective parts will be replaced and become the property of Steeffort.

Transportation costs related to freight and or delivery of replacement parts, and or whole goods maybe an additional charge at the expense of the owner.

WARRANTY EXCLUSIONS

- Any damage which results from neglect of periodic maintenance specified by Steeffort.
- Any damage resulting from repair or maintenance by methods other than specified by Steeffort.
- Any product which has participated in a competition racing or rally event.
- Any damage which results from misuse and or use beyond the limitations of the intended purpose specified by Steeffort, such as overloading, and or under abnormal conditions.
- Any damage resulting from the use of non-genuine parts, lubricant or fluid not approved by Steeffort.
- Any damage resulting from modification or installation in other products in a way that is not approved by Steeffort that has an influence on the function and/or performance of the products.
- Any damage that results from operating under conditions that are not specified in the Owner's Manual either intentionally or by error.
- Fading of painted surfaces, deterioration of plated surfaces, deterioration of rubber and plastics including, rusting due to the passage of time.

- Normal phenomena such as noise, vibration and or oil, are considered by Steelfort as not affecting the quality, function or performance of the product.
- Any damage due to improper storage and or transport.
- Consumable replacement items: Spark plugs, contact points, shear pins, fuel strainers, oil filter elements, air cleaner elements, brake shoes or pads, clutch components, fuses, motor brushes, gaskets, tube or hoses, belts, cutting blades, light bulbs, serviceable bearings. Petroleum and others fluids: Oil, grease, battery electrolyte, and radiator coolant. Other items specified by Steelfort.
- Periodical maintenance items such as cleaning, inspection and adjustments.
- Any repair and/or adjustment performed by persons other than an authorised LawnMaster dealer, or damage resulting therefrom. All maintenance and repairs conducted by unauthorised service dealers and or persons will void the warranty.
- Any repair and/or adjustment to correct improperly and or poor-quality work that is previously performed.
- Incidental expenses that are incurred in the warranty claim for additional expenses such as towing, communications, accommodation and meals, that are incurred due to the breakdown of the product at a remote location are not covered.
- Any expense related to personal injury and/or property damage, (exclusive of the product itself). Compensation for loss of time, commercial losses or rental costs of a substitute product during the period of adjustment.
- Any damage which results from unavoidable natural disasters, fire, collision, theft, etc.
- Any normal wear or deterioration, such as that of sliding and or rotating parts caused under normal operating conditions i.e., normal wear to pistons, piston rings, cylinder bores, piston pins, valve seats, stems and bearings.
- Any damage resulting from exposure of the product to soot and smoke, medicines and chemical agents, seawater, sea breeze, salt or other environmental phenomena

DOMESTIC USE:

Personal, residential or household use only and is covered by a 3-year warranty. NOTE: These warranty conditions apply in New Zealand only.

COMMERCIAL USE:

All uses other than domestic use, including use for income-producing (including farming) or rental purposes have a 90-day warranty. NOTE: These warranty conditions apply in New Zealand only.

LawnMaster®

FIND US



www.lawnmaster.co.nz



lawnmasternz

Steelfort

500 Rangitikei Street, Private Bag 11045
Palmerston North, 4412, New Zealand
06 350 1350

Steelfort Auckland

880 Great South Road, Penrose
Auckland, 1061, New Zealand
09 573 1324