

LawnMaster®

SAFETY AND OPERATING MANUAL



SPLIT SHAFT BRUSH CUTTER

LMDGJ260H-BC

LMDGJ260H-BK

PREFACE

This manual explains how to operate the Split-Shaft Petrol Brush Cutter. Before operating the unit, please ensure you read this manual carefully and acknowledge all safety elements before operating. Understanding how to repair and maintain the unit will help you operate and complete the task safely.



SAFETY FIRST

Instructions in this manual marked with a danger/warning sign, are hazards or concerns that must be taken into consideration when operating the unit to prevent possible serious injury. Please carefully read all instructions and operate the unit accordingly.



IMPORTANT

The '!' indicates instructions that must be followed, to prevent mechanical failure, breakdown, or damage.



NOTE

The notebook indicates helpful tips, hints or directions when using the product.

TABLE OF CONTENTS

Preface	02
Table Of Contents	02
Parts Location	03
Specification	04
Unit Labels	05
For Safe Operations	05
Set-Up	08
Fuel & Chain Oil	10
Operation	11
Maintenance	18
Storage	22
Troubleshooting Guide	23

1. PARTS LOCATION

LMDCJ260H-BC

1. Loop handle
2. Shoulder strap hanger
3. On/Off switch
4. Throttle cable
5. Throttle Trigger
6. Throttle set button
7. Drive shaft housing
8. Connector Bolt
9. Spark arrester
10. Starter Handle
11. Fuel tank
12. Primer pump
13. Choke level
14. Air cleaner cover
15. Debris guard
16. Gear case
17. Cutting head
18. Blade
19. Gear case
20. Guide bar
21. Saw chain
22. Chain cover
23. Gear case

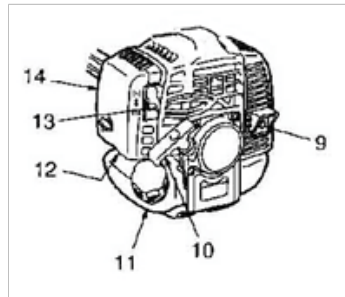
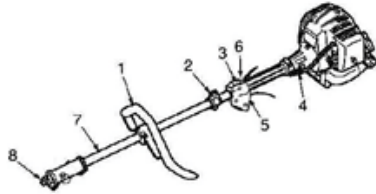

Additional Attachments

Can be bought separately or included with the Brush Cutter Kit

LMDCJ260H-BC

BC-EX

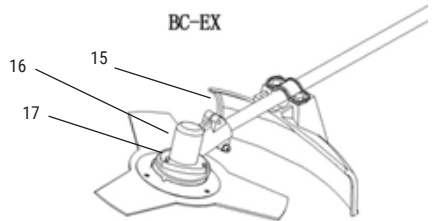

LMDCJ260H-PS

PS-EX

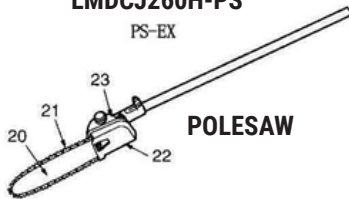

POLESAW

LMDCJ260H-HT

LRT-EX

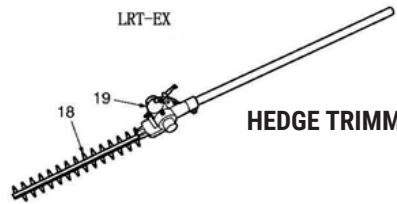

HEDGE TRIMMER

LMDCJ260H-E



EXTENSION

2. SPECIFICATIONS

MODEL	LMDCJ260H-BC
Displacement:	26cc
Max Output:	0.9 kw,7000 r/min
Idle Speed:	2800 + - 200/min-1 (rpm)
Fuel:	Mixture (Petrol 40: Oil 1)
Spark Plug:	Champion RCJ6Y
Fuel Tank Capacity:	0.7L

MODEL	BC-EX (BRUSH CUTTER)
Overall Size(L×W×H):	1790×250×310mm
Dry Weight W/O Acc:	5.3kg
Transmission	Centrifugal clutch, rigid drive shaft
Reduction Ratio:	1.294
Cutting Head Rotating Direction:	Counter-clockwise (Operator view)

LMDCJ260H-BC

MODEL	LRT-EX (HEDGE TRIMMER)
Overall Size(L×W×H):	2300×250×310mm
Dry Weight W/O Acc:	6.1kg
Transmission	Centrifugal clutch, rigid drive shaft
Reduction Ratio:	4.0
Cutting head:	
Type:	Reciprocating Double blade
Tooth:	28 Teeth
Pitch:	30mm
Effective Cut Width:	40mm
Angle Adjust Range:	90 degrees (45 from cutting head position aligned shaft)

LMDCJ260H-HT

MODEL	PS-EX (POLE SAW)
Overall Size(L×W×H):	2100×250×310mm
Dry Weight W/O Acc:	5.05kg
Transmission	Centrifugal clutch, rigid drive shaft
Reduction Ratio:	0.94
Cutting Head:	Counter-clockwise (Operator view)
Sprocket:	7T
Oil Pump:	Plunger Type
Type of Chain:	40DL 3/8LP X 0.050" (ProKut PPGAF20S040DL)
Bar Length:	254mm (10")

LMDCJ260H-PS

SPECIFICATIONS ARE SUBJECT TO CHANGE WITHOUT NOTICE.

3. LABELS ON THE UNIT



Read owner's manual before operating this unit.



Wear head, eye and ear protection.



Warning/Attention

Keep all children, bystanders and helpers 15 meters away from the unit.

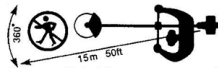

Do not modify the unit, this will result in the warranty being void.

Follow the instructions for changing the accessories. The use of any other accessories or attachments may cause a potential hazard or injury to the user, damage to the unit and void this warranty.

4. SYMBOLS ON THE Unit

Read the manual before operating the unit and keep the information for future reference to learn safe operating techniques. For safe operation and maintenance, symbols are helpful indications and tips.



The port to refuel the "MIX PETROL"
Position: FUEL TANK CAP



The direction to close the choke
Position: AIR CLEANER COVER



The direction to open the choke
Position: AIR CLEANER COVER



(PS-EX Only)

If you turn the rod by screwdriver follow the MIN & MAX arrow to the "MAX" position, the chain oil flow more, and if you turn to the "MIN" position, less.

Position: Bottom of the GEAR CASE

5. FOR SAFE OPERATION



Read the "Rules for Safe Operation" with care and follow the instructions in the manual to operate the unit safely. Read and be thorough with the basic controls and functions of the unit. It is important that you know how to stop and to shut off the engine, and to unhook a harnessed unit quickly.

Do not allow anyone without proper instruction or training to operate the unit. All operators of the unit should wear appropriate foot, leg, eye, face and hearing protection.

Do not rely on the debris shield on the unit to protect your eyes from thrown objects. Keep the area clear of bystanders, children and pets. Never allow children to operate or play with the unit.

5.1 WORKING CONDITION

1. When using the unit, please ensure you wear appropriate clothing and safety equipment as listed:

- (1) Helmet
- (2) Ear Muffs
- (3) Protection goggles
- (4) Thick work gloves
- (5) Non-slip-sole work boots

2. Other important tools and resources to have with you include:

- a) Approved Brush Cutter Attachments
- b) Reserve fuel
- c) For commercial use, hazard signage and rope to cordon working area.
- d) Whistle (Collaboration or emergency).

3. In addition to head, eye, face and ear protection, please wear appropriate footwear to protect your feet and to improve footing on slippery surfaces. Do not wear open-toed footwear, or go bare foot or bare legged. Do not wear ties, jewelry, or loose, dangling clothing which could be caught in the unit.

Do not allow anyone without proper instruction or training to operate the unit. All operators of the unit should wear appropriate foot, leg, eye, face and hearing protection.

Do not rely on the debris shield on the unit to protect your eyes from thrown objects. Keep the area clear of

bystanders, children and pets. Never allow children to operate or play with the unit.

5.2 WORKING CIRCUMSTANCE

1. Never start the engine inside a closed room or building. Exhaust fumes contain carbon monoxide which is a health risk.

2. Never use the product:

(a) When the ground is slippery and you cannot maintain a steady posture.

(b) At night, fog, or when your vision might be limited so it becomes difficult to gain a clear view of your working area.

(c) During storms, rainy weather, and or strong or gale-force winds. Do not use the unit if the weather conditions might make it unsafe to operate.

5.3 WORKING PLAN

1. DO NOT use the Brush Cutter under the influence of alcohol, exhaustion or lack of sleep. Do not use the unit if you are unwell or drowsy as a result of taking medication.

2. When using the brush cutter, allow plenty of time to rest. Limit your working sessions to 30-40 minutes, and take 10-20 minutes of rest in-between each working session. Keep the total amount of work performed in a single day to under 2 hours.



WARNING

1. If you don't observe the working time, or working manner when using the Brush Cutter Repetitive Stress Injury (RSI) could occur.
2. If you feel discomfort, redness and swelling of your fingers or any other part of your body, seek medical advice as soon as possible.
3. To avoid noise complaints, in general, operate product between 8 am and 5 pm on weekdays and weekends.



NOTE

Check and follow local regulations regarding appropriate sound levels and hours of operations

5.4 BEFORE STARTING THE ENGINE

1. Do not allow anyone to enter the operating DANGER ZONE with you. The danger zone is an area 15 meters in radius (about 16 paces) or 50 feet. Insist that a person near the danger zone wear eye protection from thrown objects.
2. If the unit must be used where there are unprotected people, operate at a low throttle speed to reduce the risk of thrown objects.
3. Check the working area to avoid any accidents such as hitting hidden obstacles i.e., stumps, stones, cans, or broken glass.



IMPORTANT

- Remove any obstacles before operating the unit.
- Inspect the unit and check for loose parts and fuel leakage.
- Make sure cutting attachments are properly installed and securely fastened.
- Be sure to check whether the debris guard is firmly attached and in place.
- Always use the shoulder strap. Adjust the strap for comfort before starting the engine. The strap should be adjusted so the left hand can comfortably hold the handlebar grip, approximately waist high

5.5 STARTING THE ENGINE

1. Keep bystanders and animals at least 15m away from the operating point. If you are approached immediately stop the engine.
2. The product is equipped has a centrifugal clutch mechanism; the cutting attachment begins to rotate as soon as the engine is started when the throttle is placed into the 'start position'.
3. When starting the engine, firstly place the product on the ground (flat clear area). Hold it firmly in place to ensure that neither the cutting part nor the throttle comes into contact with any obstacles when the engine starts.



WARNING

NEVER PLACE THE THROTTLE INTO THE HIGH-SPEED POSITION WHEN STARTING THE ENGINE.

4. After starting the engine, check to make sure the cutting attachments stop rotating when the throttle is moved fully back to its original position. If the cutting attachment continues to rotate even after the throttle has been moved fully back, immediately turn off the engine and take the unit to a service dealer for repair and service.

5.6 USING THE PRODUCT

IMPORTANT

Cut only materials recommended by the manufacturer to avoid any warranty concerns. Only use the Brush Cutter on tasks explained in the manual.

1. Grip the handles firmly with both hands. Place your feet slightly further than your shoulder width to distribute weight evenly across both legs to maintain a steady posture when operating the unit.
2. Keep the Brush Cutter and the cutting attachment waist low when operating the unit.
3. Maintain the speed of the engine at the level required to perform cutting work, and never raise the speed of the engine above the level necessary.
4. If the unit starts to shake or vibrate. Turn off the engine and thoroughly check the unit. Do not use the unit until the trouble has been properly fixed or take it to a service dealer for repair.
5. Keep all parts of your body away from the rotating cutting attachments and hot surfaces.
6. Never touch the muffler, spark plug, or other metallic parts of the engine while the engine is in operation or immediately after shutting down the engine. Doing so could result in serious burns or electrical shock.
7. Be prepared at all times for any hazardous situations. Warn adults to keep pets and children away from the working area. Be careful and aware if you are being approached as an injury would occur as a result of flying debris.
8. If someone calls out or otherwise interrupts you while working, always be sure to turn off the engine before giving them your attention.

5.7 MAINTENANCE

1. In order to maintain the Brush Cutter in proper working order, perform regular servicing and maintenance.
2. Always turn off the engine when performing any servicing or maintenance.



WARNING

The metallic parts reach high temperatures immediately after stopping the engine.

3. When replacing cutting attachments or any other unit parts, including oil or any lubricants, be sure to use only authorized dealer products.
4. In the event any part must be replaced, maintenance or repair work not described in this manual must be performed, contact your local service dealer for assistance.
5. Do Not use any other attachments other than the attachments recommended with the unit.
6. Do Not take apart the product or alter it in any way. Doing so will void warranty and might result in having an unsafe product that does not function properly.

5.8 HANDLING FUEL

1. The engine of product is designed to run on mixed fuel which is highly flammable. Never store fuel cans or refill the tank near a boiler, stove, wood fire, electrical sparks, welding sparks, or any other source of heat or fire which might ignite the fuel.
2. Never smoke while operating the unit or refilling with fuel.
3. When refilling with fuel, always turn off the engine and allow it to cool down before refueling.
4. Wipe spilled fuel completely using a dry rag if spillage occurs.
5. After refueling, screw the fuel cap tightly and carry the unit to a spot 3m away from where it was initially refueled before turning on the engine.

5.9 TRANSPORTATION

1. When hand-carrying the Brush Cutter, cover the cutting blades if necessary. Lift the Brush Cutter and carry it with attention to the blade.

- Never transport the product over rough roads or over long distances by vehicle without removing all fuel from the fuel tank. In doing so, might result in fuel leaks from the tank during transport.

6. SET-UP



6.1 MOUNTING ENGINE

- Push the drive shaft housing towards the clutch housing and rotate it by hand to check that the drive shaft is engaged with the gears.
- Insert the drive shaft housing into the clutch housing until it bottoms, and aligns the positioning holes on the clutch housing and the shaft tube and install the screw. When difficult to engage, twist the engine slightly.
- Fasten the clamp securely with two screws. Tighten the screws gradually by turns.

! IMPORTANT

Connecting switch wires, connect the switch wires between the engine and the main. Pair the wires of the same colour.

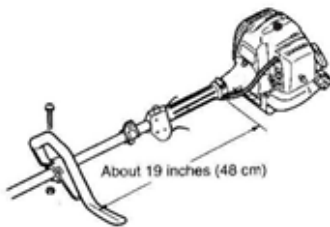

6.2 INSTALLING HANDLE (BC-EX, LRT-EX)

- Install the handle to the shaft tube and clamp at the location that is comfortable to you. (PS-EX only)
- Insert the grip to the shaft tube.
- Fasten the clamps with screws.

6.3 JOINT ATTACHMENT

- Insert the attachment to the main shaft.
- Tighten the knob bolt securely Set up (BC-EX only)

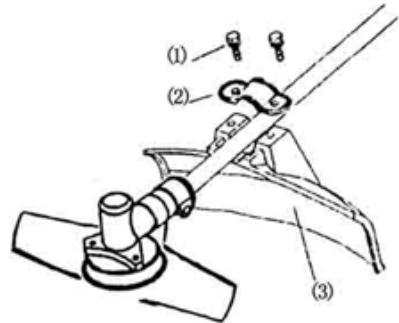
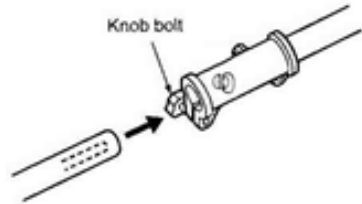
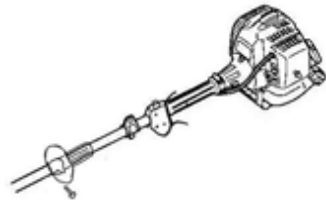

6.4 INSTALLING DEBRIS GUARD

- Screw
- Plate
- Debris guard

Put the debris guard on the gearbox, attach it with the 2 screws and hardware provided.

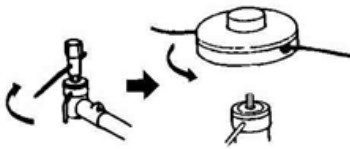

6.5 INSTALLING CUTTING HEAD

1. While locking the gear shaft, by inserting the supplied tool into the upper holder on the gearbox, loosen and remove the hexagon nut (left-handed).
2. Then screw in the cutting head to the gear shaft over the holders. Hand-tighten it securely.



6.5.1 BALANCE UNIT

1. Put on the Brush Cutter strap and attach the unit to the strap.
2. Slide clamp up or down until the unit balances by slightly touching the ground. **Set up (LRT-EX only)**

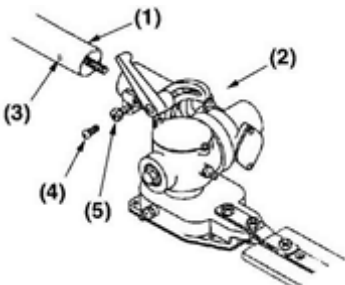

6.6 ATTACHING THE TRIMMING MECHANISM

- (1) Main pipe
- (2) Trimming mechanism
- (3) Screw hole
- (4) Screw
- (5) Fastening bolt

1. Remove the screw that is screwed into the end of the trimming mechanism.
2. Insert the end of the trimming mechanism into the main pipe.
3. Line up the hole on the end of the trimming mechanism to the screw to be inserted with the hole on the main pipe - screw it in firmly.
4. Using a wrench, screw in the bolt provided to fix the trimming mechanism into place.

6.6.1 BALANCE UNIT

1. Put on the Brush Cutter strap and attach the unit to the strap.
2. Depending on the working posture, slide clamp up or down until the unit balances and the straps comfortably to your body. **Set up (PS-EX only)**

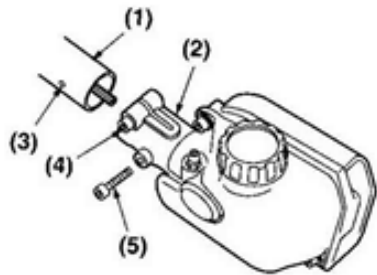

6.7 ATTACHING THE PRUNING MECHANISM

- (1) Main pipe
- (2) Gear case
- (3) Screw hole
- (4) Fastening bolt
- (5) Bolt

1. Remove the cap on the end of the main pipe.
2. Remove the screw that is screwed into the end of the gear case.

3. Insert the end of the trimming mechanism into the main pipe.
4. Line up the hole on the end of the gear case to the screw that is to be inserted with the hole on the main

6.7 ATTACHING THE PRUNING MECHANISM

- (1) Main pipe
- (2) Gear case
- (3) Screw hole
- (4) Fastening bolt
- (5) Bolt

1. Remove the cap on the end of the main pipe.
2. Remove the screw that is screwed into the end of the gear case.
3. Insert the end of the trimming mechanism into the main pipe.
4. Line up the hole on the end of the gear case to the screw that is to be inserted with the hole on the main pipe, and screw it in firmly.
5. Using a wrench, screw in the bolt provided to fix the mechanism into place.

7. FUEL AND CHAIN OIL

7.1 FUEL

1. Petrol is very flammable. Avoid smoking or bringing any flames or sparks near fuel.
2. Make sure to stop the engine and allow it cool before refueling the unit.
3. Select outdoor bare ground for fueling and move at least 3m (10ft) away from the fueling point before starting the engine.
4. The engines are lubricated by oil specially formulated for air-cool 2-cycle Petrol engine use. If oil is not available, use an anti-oxidant added quality oil expressly labeled for air-cooled 2-cycle engine use.
5. Do not use BIA or TCW (2-stroke water-cooling type) mixed oils.

7.1 SUMMARY

The engine uses two-stroke fuel. If you have emission requirements, the mixture ratio of the fuel to oil should be 40:1. If there are no emission requirements, the mixture ratio can be 25:1.

Petrol

Use 91 Unleaded Petrol.
Other Appropriate Fuel Mixtures

Petrol	2-Stroke Oil
1 Litre	25 ml
2 Litre	50 ml
5 Litre	125 ml

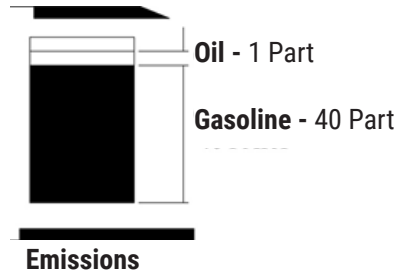

7.2 HOW TO MIX FUEL



WARNING

Pay attention to agitation.

1. Measure out the quantities of petrol and oil to be mixed.
2. Put some of the petrol into a clean, approved fuel container.
3. Pour in all of the oil and agitate well.
4. Pour in the rest of the petrol and agitate again for at least one minute. Some oils may be difficult to agitate depending on oil ingredients, sufficient agitation is necessary for the engine to last long. Be careful that, if the agitation is insufficient, there is an increased danger of early piston seizing due to abnormally lean mixture.
5. Put a clear indication on the outside of the container to avoid mixing of petrol or other containers.
6. Indicate and name the contents on the container for easy identification.

7.3 FUELING THE UNIT

1. Untwist and remove the fuel cap. Rest the cap on a dustless area.
2. Put fuel into the fuel tank to roughly 80% of the full capacity. Do not over fill.
3. Fasten the fuel cap securely and wipe any fuel spillage around the unit.



WARNING

- When fueling, do it on a flat and bare ground.
- Move at least 3m away from the fueling point before starting the engine.
- Stop the engine before refueling the unit and be sure to sufficiently agitate the mixed petrol in the container.

7.4 PRESERVE ENGINE LIFE, AVOID:

1. **FUEL WITH NO OIL (RAW PETROL)**
Will cause severe engine damage to the internal engine parts very quickly.
2. **OIL FOR 4-CYCLE ENGINE USE,**
Can cause spark plug fouling, exhaust port blocking, or piston ring sticking.
3. Mixed fuels that have been left unused for a period of one month or more may clog the carburettor and result in the engine failing to operate properly.
4. When storing the product for a long period of time, clean the fuel tank after rendering it empty.
5. When scrapping used mixed oils, follow your local council protocols and visit a repository site.



NOTE

For details of quality assurance, read the description in the section limited to warranty carefully.

Normal wear and tear of the product with no functional influence is not covered by warranty. Do not make mistakes when mixing oil and petrol, follow the instructions in the manual to avoid warranty issues.

7.5 CHAIN OIL



NOTE

Do not use wasted or regenerated oil as this can cause damage to the oil pump.

8. OPERATION

8.1 STARTING ENGINE

CAUTION

Do not pull the starter cord all the way out and do not let go of the starter handle when the cord is extended, this can damage the starter mechanism.

Before starting the engine, inspect the entire unit for loose fittings or fuel leaks, and verify that the cutting attachment is properly installed and securely fastened.

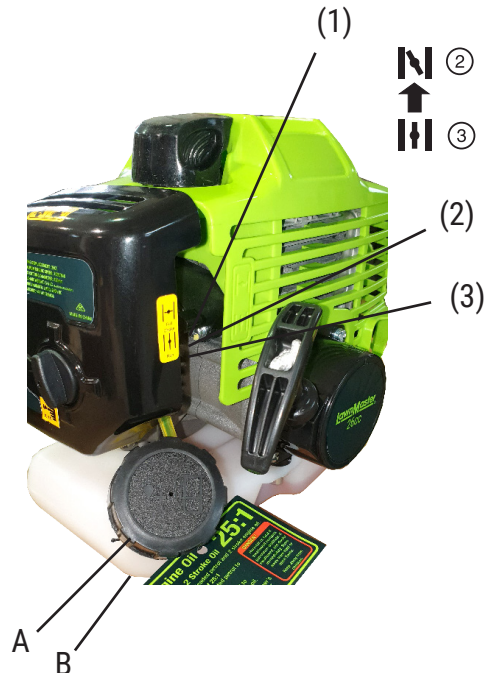

8. OPERATIONS

8.1 STARTING ENGINE

CAUTION

Do not pull the starter cord all the way out and do not let go of the starter handle when the cord is extended, this can damage the starter mechanism.

Before starting the engine, inspect the entire unit for loose fittings or fuel leaks, and verify that the cutting attachment is properly installed and securely fastened.

WARNING

The cutting head will start rotating upon the engine starting.

Place the unit on a flat, firm place. Keep the cutting head clear of any obstructions.

1. Check that there is fuel in the tank and that the fuel cap is screwed on tightly. (See Image - Point 5).

(A) Cap
(B) Fuel tank

2. Fill fuel into the fuel tank and tighten the cap securely.

3. Feed the chain oil into the oil tank and tighten the cap securely. (PS-EX only)

4. Rest the unit on a flat, firm area. Keep the cutting head off the ground and clear of surrounding objects, as it will start rotating upon engine starting.

5. When Cold Starting, move the choke lever to the closed position.

(1) Choke lever

(2) Close

(3) Open

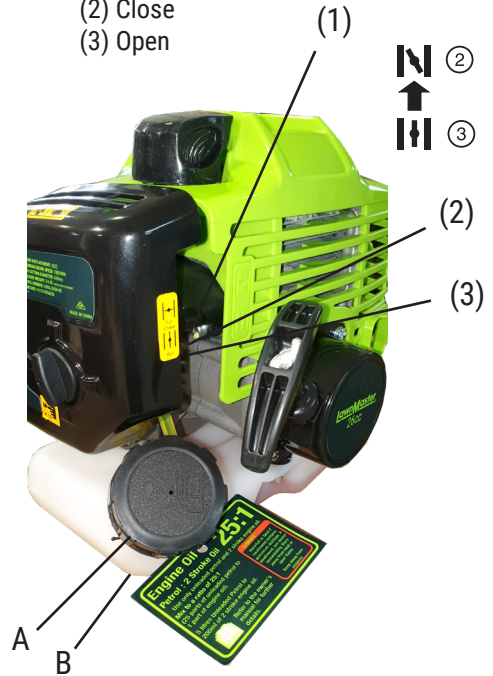

6. If the engine has been running and is still warm, move the choke lever to the open position.

7. Press the priming bulb under the carburettor repeatedly until excess fuel can be seen returning to the tank through the clear fuel return pipe.

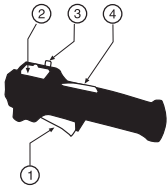

BC 230B S2, BC 260 S2 and
BC 260B S2



BC 325 S2

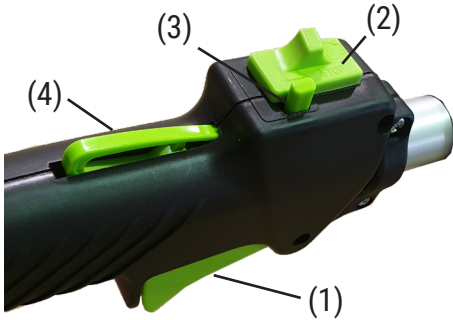

8. Slide the ignition switch (2) on the trigger grip away from the STOP position

9. To set the throttle in the start position.
- Depress the safety lever (4) and squeeze the throttle lever (1) fully. Hold down the starting button (3). Releasing the throttle lever and then the starting button.
- The throttle lever will be held partly open until it is squeezed again.

- (1) Throttle lever
- (2) Ignition Switch
- (3) Starting button.
- (4) Safety Lever

10. While holding the unit firmly, pull out the starter rope quickly.

11. After the engine has started, open the choke gradually.

12. Allow the engine to run for 2 to 3 minutes to warm up before starting work.

NOTE - OVERCHOKING

- Should the engine become flooded due to over-choking set the ignition switch to the STOP (2), unscrew the spark plug, wipe it dry or replace, pull the recoil starter several times without the spark plug in place and with the choke in the open position. This will help clean and ventilate the combustion chamber.

8.2 STOPPING THE ENGINE

- Set the engine to idling by releasing the throttle lever.
- Set the ignition switch to the STOP (2) position.
- If the engine fails to stop, set the choke lever to the closed position to stall the engine; do not use the machine until the ignition switch is repaired.

RUNNING IN

- During the first ten hours of work, avoid running the engine at maximum speed for a prolonged period until all the components have bedded in. After the engine has been run-in, it will reach its maximum power.

! WARNING

The cutting head will start rotating upon the engine starting.

Place the unit on a flat, firm place. Keep the cutting head clear of any obstructions.

1. Check that there is fuel in the tank and that the fuel cap is screwed on tightly. (See Image - Point 5).

- (A) Cap
- (B) Fuel tank

2. Fill fuel into the fuel tank and tighten the cap securely.

3. Feed the chain oil into the oil tank and tighten the cap securely. (PS-EX only)

4. Rest the unit on a flat, firm area. Keep the cutting head off the ground and clear of surrounding objects, as it will start rotating upon engine starting.

5. When Cold Starting, move the choke lever to the closed position.

- (1) Choke lever
- (2) Close
- (3) Open

6. If the engine has been running and is still warm, move the choke lever to the open position.

7. Press the priming bulb under the carburettor repeatedly until excess fuel can be seen returning to the tank through the clear fuel return pipe.

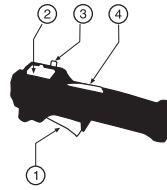

BC 230B S2, BC 260 S2 and
BC 260B S2



BC 325 S2

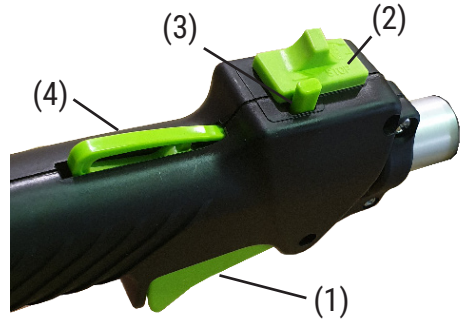

8. Slide the ignition switch (2) on the trigger grip away from the STOP position

9. To set the throttle in the start position.

- Depress the safety lever (4) and squeeze the throttle lever (1) fully. Hold down the starting button (3). Releasing the throttle lever and then the starting button.

- The throttle lever will be held partly open until it is squeezed again.

- (1) Throttle lever
- (2) Ignition Switch
- (3) Starting button.
- (4) Safety Lever

10. While holding the unit firmly, pull out the starter rope quickly.

11. After the engine has started, open the choke gradually.

12. Allow the engine to run for 2 to 3 minutes to warm up before starting work.

NOTE

OVERCHOKING

- Should the engine become flooded due to over-choking set the ignition switch to the STOP (2), unscrew the spark plug, wipe it dry or replace, pull the recoil starter several times without the spark plug in place and with the choke in the open position. This will help clean and ventilate the combustion chamber.

8.2 STOPPING THE ENGINE

- Set the engine to idling by releasing the throttle lever.
- Set the ignition switch to the STOP (2) position.
- If the engine fails to stop, set the choke lever to the closed position to stall the engine; do not use the unit until the ignition switch is repaired.

RUNNING IN

- During the first ten hours of work, avoid running the engine at maximum speed for a prolonged period until all the components have bedded in. After the engine has been run-in, it will reach its maximum power.

IMPORTANT

Except for an emergency, avoid stopping the engine while pulling the throttle lever.

8.3 ADJUSTING IDLING SPEED

1. When the engine tends to stop frequently at idling mode, turn the adjusting screw clockwise.
2. When the cutting head keeps rotating after releasing the trigger, turn the adjusting screw counter-clockwise.

NOTE

Warm up the engine before adjusting the idling speed.

8.3 OPERATION (BC-EX ONLY)

8.3.1 CUTTING WORK (LINE HEAD USE)

- Always wear eye protection such as safety goggles.
- Never lean over and look at the rotating cutting head. Rocks and or other debris could be thrown at the eyes/face and cause serious injury.
- Keep the debris guard in place at all times when the unit is operated



WARNING

- Always wear eye protection such as safety goggles.
- Never lean over and look at the rotating cutting head. Rocks and or other debris could be thrown at the eyes/face and cause serious injury.
- Keep the debris guard in place at all times when the unit is operated

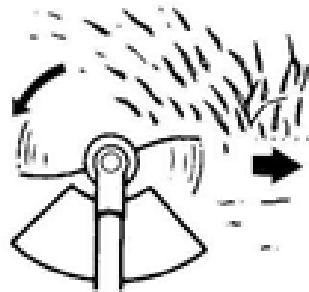

8.3.2 TRIMMING GRASS AND WEEDS

Always remember that the TIP of the line does the cutting. You will achieve better results by not crowding the line into the cutting area and allowing the unit to trim at its own pace.

1. Hold the unit so the head is off the ground and is tilted about 20 degrees towards the sweeping direction.
2. To avoid thrown debris, move the Brush Cutter in a sweeping movement from left to the right.
3. Use a slow, deliberate action to cut heavy growth. The rate of cutting motion will depend on what is being cut. Heavy growth will require a slower action in comparison to light growth.
4. Never swing the unit in an extreme motion or with physical force, this is extremely dangerous as you may lose balance or control of the unit.
5. Control the cutting motion with your hips rather than placing the full workload on the arms and hands.
6. Take extra care to avoid wires, dead or dry grass, long-stem weeds from wrapping around the head shaft. Such materials can stall the head and cause the clutch to slip, resulting in damage to the clutch system if repeated frequently.

8.3.3 ADJUSTING THE LINE LENGTH

- The brush cutter is equipped with a semi-auto type nylon line head that allows the operator to advance the line without stopping the engine. When the line becomes short, lightly tap the head on the ground while running the engine at full throttle to extend it. Each time the head is bumped, the line advances about 1 inch (25.4mm).
- For better effect, tap the head on bear ground or hard soil. Avoid bumping in thick, tall grass as the engine may stall by overload.

8.3.4 CHOOSE THE BLADE

- Choose a suitable recommended cutting attachment according to the object to be cut.
- When replacing the blade always be sure to use products, which have been certified.

WARNING

When sharpening, removing, or reattaching the blade, be sure to wear thick, sturdy gloves and use only proper tools and equipment to prevent injury.

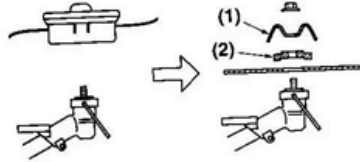

8.3.5 SET UP

- (1) Cover
- (2) Holder

1. Detach the line head assembly completely.
2. Put on the blade, making the marked side face the holder, put on the outer holders and fasten the blade with the blade nut.

8.3.6 STARTING THE ENGINE

Please refer to the manual for safe operation.

WARNING

This product is equipped with a centrifugal clutch mechanism, so the cutting attachment begins to rotate as soon as the engine is started by putting the throttle into the start position.

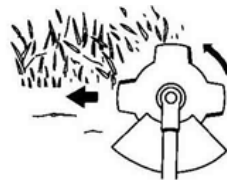

8.3.7 CUTTING METHOD

1. Use the front left side cutting.
2. Guide the blade from your right to left with it tilted slightly to your left.
3. When mowing a wide area, start working from your left to avoid interference of cut grass.
4. The blade could be seized by weeds if the

engine speed is too low, or the blade cuts too deep into weeds. It is important to adjust the engine speed and cutting depth accordingly to the challenge.

WARNING

If the grass or any other object gets caught on the blade, or if the unit starts to shake, vibrate or the engine turns off. Thoroughly check the unit before using it again and change the blade if it has been damaged. Always turn off the engine before attempting to check the blade and removing any objects that are caught or entangled on the blade.



8.4 OPERATION

1. Check the bolt to fasten the blade and be sure the bolt has no fault, and no abrasion.
2. Be sure that the blade and the holder have been fastened according to instruction and that the blade turns smoothly without abnormal noise.
3. To use the shoulder strap, hang the unit on your right side. Adjust the strap length so the cutting head becomes parallel to the ground



WARNING

8.4.1 CONTROLLING BLADE BOUNCE

Kick out can cause serious personal injury. Read this section carefully to manage and understand what causes kick outs, and how you can reduce it from happening to remain in control of the unit if it does occur.

8.4.2 WHAT CAUSES KICK OUT:

Kick out occurs when the moving blade makes contact with an object that cannot be cut. The contact causes the blade to stop for an instant and suddenly move or “bounce” away from the object that was hit.

8.4.3 HOW YOU CAN REDUCE THE CHANCE OF KICK OUT:

1. Recognize that kick out can happen by understanding and knowing about bounce to eliminate the element of surprise.
2. Cut fibrous weeds and grass only. Do not let the blade make contact with materials it cannot cut such as hard, woody vines and bushes or rocks, fences, metal, etc.
3. Be prepared for bounce if you must cut where you cannot see the blade making contact such as in areas of dense growth.
4. Keep the blade sharp. A blunt blade increases the chance of bounce.
5. Avoid feeding the blade too rapidly. The blade can bounce away from material being cut if the blade is fed faster than its cutting capability.
6. Cut only from your right to your left.
7. Keep your path in advance clear of material that has been cut and other debris.

8.4.4 HOW YOU CAN MAINTAIN THE BEST CONTROL:

1. Keep a good firm grip on the unit with both hands. A firm grip can neutralize bounce and keep your right and left hands completely around their respective handles.
2. Keep both feet spread apart in a comfortable stance and yet braced for the possibility that the unit could bounce. Do not overreach. Keep firm footing and balance.

8.4.5 MAINTENANCE

BLADE

- Check the blade and the fasteners for looseness cracking, or bending.
- Check the cutting edges and reform with s file.

Point:

1. Keep the end corner sharp.
2. Round the root of the edge, using a round file.
3. Do not use water when using a grinder.

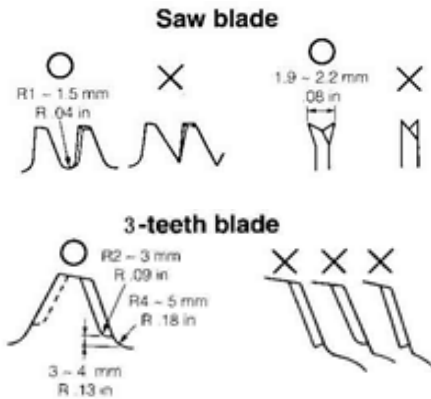

! IMPORTANT

It is recommended that all filing be completed by professionals at service dealerships as this may result in warranty being void if the unit or trimming attachments are damaged.

8.4.6 TRANSPORTING THE UNIT

- Turn off the engine every time when transporting the Brush Cutter from one location to the next paying close attention to the blade.
- Once you are finished with the unit, always remember to place the protective cover over the blades.
- If you are transporting the unit over long distances, detach the blade and fasten the unit by ropes.

8.5 OPERATION (LRT-EX ONLY)

! WARNING

This product is equipped with extremely sharp blades! If incorrectly used or handled, these blades can be very dangerous and can cause accidents that lead to serious injury or death.

For this reason, it is recommended that you take an extremely cautious approach, follow all safety procedures and instructions when using the Brush Cutter with the Hedge Trimmer attachment.

1. Do not point the hedge trimmer blades towards anyone.
2. Do not allow the blades to come into close proximity with you or anyone else when running.
3. Turn off the engine before changing the angle of the blades or having to touch the blade.
4. Always wear work gloves made of leather or other sturdy material when running the unit.
5. Always use the blade cover on the blade that is provided when not in use.
6. Wear safety equipment to protect yourself from falling trees, branches, sharp steams or flying objects. It is advised that a face protector, helmet, gloves and covered shoes are worn at all times.

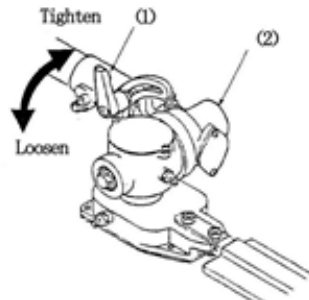

8.5.1 WHEN USING THE HEDGE TRIMMER

! IMPORTANT

When using the hedge trimmer attachment, the maximum cutting thickness of branches maybe limited to approximately 3/16" (5mm). Do not try to cut branches thicker than this, as this may result in damage to the trimmer.

ADJUSTING THE ANGLE OF THE CUTTING BLADES

- (1) Clamp lever
- (2) Trimming mechanism

1. Stop the engine.
2. Turn the bolt located on the top of the trimming mechanism counterclockwise to loosen it.
3. Adjust the angle of the blades to the desired angle, and fix the bolt firmly back into place.

8.6 OPERATION (PS-EX ONLY)

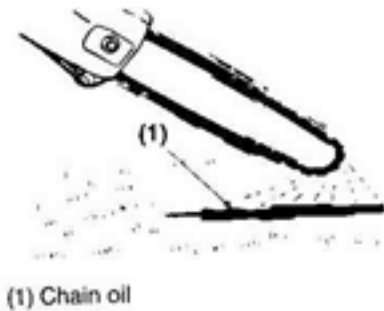

8.6.1 CHECKING OIL SUPPLY

When using the Pole Saw attachment, after starting the engine, run the chain at medium speed and see if chain oil splatters off in a forward direction as shown in the figure.

The oil reservoir has the capacity to provide 40 minutes of cutting time (based on minimum flow rate, or from a tank of fuel). Be sure to regularly refill oil when refueling the saw and use Genuine Chain Bar Oil.

8.6.2 ADJUSTING OIL FLOW RATE



WARNING

Do not fill the oil reservoir or adjust the oiler when the engine is in operation or running.



IMPORTANT

An increase in bar oil flow rate will speed up oil consumption thus resulting in more frequent checks on the oil reservoir. To ensure sufficient lubrication, it may be necessary to check oil levels more regularly in comparison to fuel tank refills.

The guide bar and chain are lubricated automatically by a pump that operates when the chain rotates. The pump is set at the factory to deliver a minimum flow rate, but this can be adjusted. A temporary increase in oil flow is often desirable when cutting dense material such as hardwood or wood with a lot of pitch.

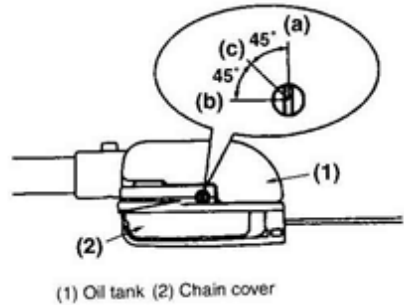

8.6.3 ADJUST THE PUMP AS FOLLOWS:

1. Stop the engine and make sure the stop switch is in the OFF position.
2. Place the unit on its side with the oil reservoir up.



IMPORTANT

The oil flow adjusting screw must be pressed in slightly in order to turn. Failure to do so could damage the pump and screw.

3. With a screwdriver, push-in on the oil flow rate adjusting screw and turn-in on the desired direction (there are three incremental settings):

- (a) Clockwise-decrease lubrication
- (b) Counter clockwise-increase lubrication
- (c) Middle

9. MAINTENANCE

WARNING

Make sure the engine has stopped and has cooled down before performing any servicing to the unit. Contact with moving cutting head or hot muffler may result in a personal injury.

9.1 AIR FILTER

The air filter, if clogged, will reduce engine performance. Check and clean the filter element in warm soapy water as required and dry completely before installing. If the element is broken or shrunk, replace with a new one.

9.2 FUEL FILTER

When the engine runs short of fuel supply, check the fuel cap and the fuel filter for blockage

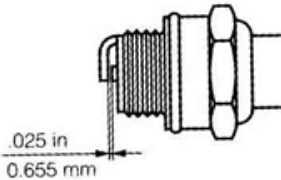

9.3 SPARK PLUG

Starting failures and misfiring are often caused by fouled spark plugs. Clean the spark plug and check that the plug gap is in the correct range. For a replacement plug, use the correct type specified.

IMPORTANT

Using any spark plug other than those designated may result in the engine failing to operate properly or becoming overheated and damaged.

To install the spark plug, first turn the plug until it is finger tight, then tighten it a quarter turn more with a socket wrench.

TIGHTENING TORQUE: (9.8-11.8N.m.).

9.4 MUFFLER

WARNING

Periodically inspect the muffler for loose fasteners, damage or corrosion.

If any sign of exhaust leakage is found, stop using the unit and have it repaired immediately with a Service Dealer. Failing to do so may result in the engine catching on fire.



(1) Spark arrester

9.5 SPARK ARRESTER

The muffler is equipped with a spark arrester to prevent red hot carbon from flying out of the exhaust outlet.

Periodically inspect and clean as necessary with a wire brush.

9.6 INTAKE AIR COOLING VENT

WARNING

- Do not touch the cylinder, muffler, or spark plugs with your bare hands immediately after using the unit when the engine is hot. The engine can become very hot during operation, and doing so could result in severe burns.
- Before a working session, thoroughly inspect the unit before use. Check specific areas around the muffler and remove any wood chips or leaves which have become attached. Failing to do so could result in the muffler overheating and in turn could cause the engine to catch on fire.
- After every 25 hours of use, check the intake air cooling vent and the area around the cylinder

cooling fins for blockage. Remove any waste which has attached itself to the Brush Cutter. It is necessary to remove the engine cover shown in the image in order to view the upper part of the cylinder.

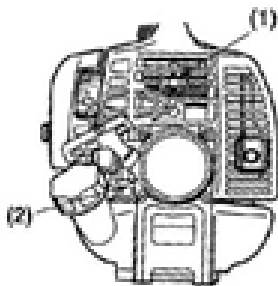

(1) Cylinder
(2) Intake air cooling vent (back)

! IMPORTANT

If waste gets stuck and causes blockage around the intake air cooling vent or between the cylinder fins, may cause the engine to overheat, leading to mechanical failures.



9.7 PROCEDURES TO BE PERFORMED AFTER EVERY 100 HOURS OF USE

1. Remove the muffler, insert a screwdriver into the vent, and wipe away any carbon build-up on the muffler exhaust vent and cylinder exhaust port at the same time.
2. Tighten all screws, bolts, and fittings.
3. Check to see if any oil or grease has worked its way in between the clutch lining and drum, and if it has, wipe it away using oil-free, lead-free Petrol.

9.8 MAINTENANCE (BC-EX ONLY)

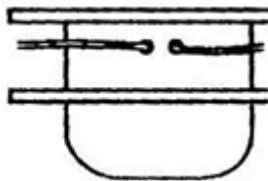

9.8.1 REFILLING TRIMMING LINE

1. For a replacement line, use a diameter of 2.4 mm. Avoid using a larger line as it may cut down the trimming performance.

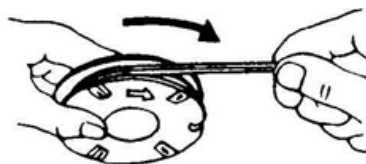
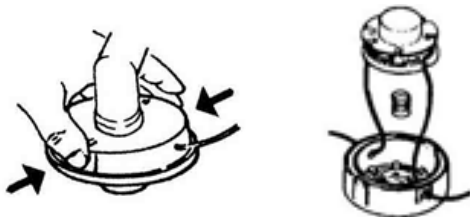

! WARNING

For safety reasons, do not use metal reinforced line.

2. Pinch the slotted area on both sides of the spool housing to unhook the bottom cap.
3. Take out the spool and pull off remaining old line. Then cut 4m of line as replacement.
4. Take out the spool and pull off the old line. Put one end of new line through the spool holes and pull it until the length is equal between each part of the line.
5. Wind up the line in the correct direction as indicated on the spool.
6. Hook each end of the line into the slots on the edge of the spool, and then put the ends through the eyelets on the housing. Make sure that the spring and the washers are in place.

7. While holding the spool against the housing, pull the line ends to release them from the slot.
8. Line up the slot on the bottom cap with the hook on the housing; press the cap against the housing until it clicks.

NOTE

If the screw is too tight, it may make it impossible for the blades to move. Also, if the screw is too loose it may make the blades feel dull and cause leaves and branches to be caught in the blades of the trimmer.

9.8.2 GEAR CASE

- The reduction gears are lubricated by multipurpose, lithium-based grease in the gear case.
- Supply new grease every 25 hours of use or more often depending on the job condition.
- Remove the cutter holders before installing new grease to arrange for old grease to exit.

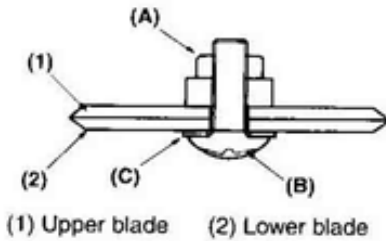

(1) Grease fitting

9.8.2 GEAR CASE

The reduction gears are lubricated by multipurpose, lithium-based grease in the gear case. Supply new grease every 25 hours of use or more often depending on the job condition. When adding lubricant, use a grease gun to insert lubricant into the three grease nipples located on the gear case.

9.8 MAINTENANCE (LRT-EX ONLY)

9.8.1 BLADES

- When refilling the tank or resting, it is often a good idea to use the time to oil the cutting blades.
 - If a gap exists between the upper and lower blades, follow the procedure below to adjust them so that they fit more closely together.
1. Loosen lock nut (A) as shown in the diagram.
 2. Tighten screw (B) fully, and then turn one-third to one half of a rotation backward.
 3. While holding onto the screw to keep it in position, tighten the lock nut.
 4. Check to make sure that the flat washer (C) is loose enough so that it may be turned by pressing on it with a finger.

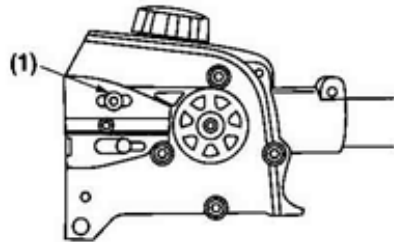

(1) Oiling port

9.9 MAINTENANCE (PS-EX ONLY)

9.9.1 OILING PORT

Dismount the guide bar and check the oiling port for clogging.

9.9.2 GUIDE BAR

Remove sawdust in the bar groove and the oiling port. (Type: Sprocket nose)

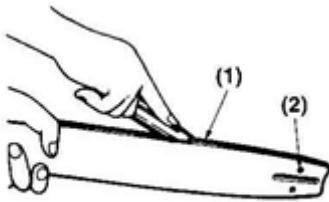

(1) Groove (2) Oiling port

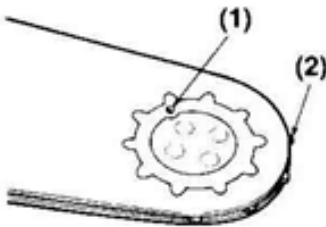

(1) Grease port (2) Sprocket

Grease the nose sprocket from the feeding port on the tip of the bar. The bar rail should always be square. Check for wear on the bar rail. Apply a ruler to the bar and the outside of a cutter. If a gap is observed between them, the rail is normal. Otherwise, the bar rail is worn. Such a bar needs to be corrected or replaced.

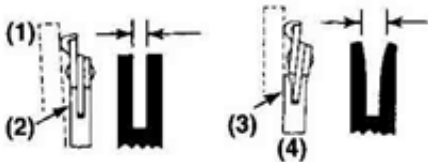

(1) Ruler (2) Gap
(3) No gap (4) Chain tilts

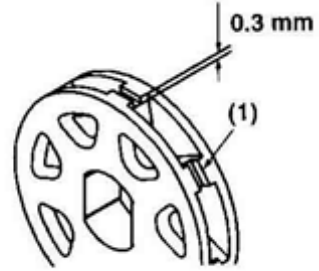

(1) Sprocket

9.9.3 SPROCKET

Check for extensive wear, and replace it when the teeth are worn over 0.3mm

9.9.4 SAW CHAIN

⚠ WARNING

For smooth and safe operation, it is important to keep the cutters sharp. Your cutters need to be sharpened when:

- Sawdust becomes powder-like.
- You need extra force to complete jobs.
- The cutting direction does not go straight.
- Vibration increase.
- Fuel consumption increase.

9.9.5 CUTTER SETTING STANDARDS:

⚠ WARNING

Be sure to wear safety gloves.

Before filling:

- Make sure the chain is held securely.
- Make sure the engine is stopped.
- Use a round file of proper size for your chain.

Place your file on the cutter and push straight forward. Keep the file position as illustrated. After every cutter has been set, check the depth gauge and file it to the proper level as illustrated.

- (1) Appropriate gauge checker
- (2) Make the shoulder round
- (3) Depth gauge standard

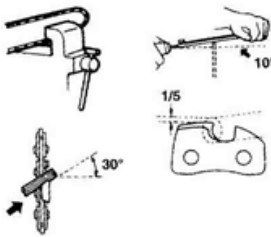
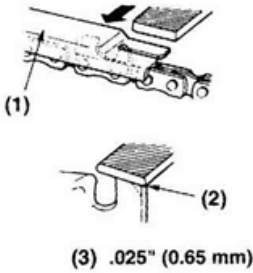

WARNING

Be sure to round off the front edges to reduce the chance of kickback or tie-strap breakage. Make sure every cutter has the same length and edge angles as illustrated.

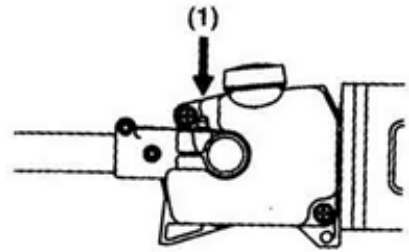
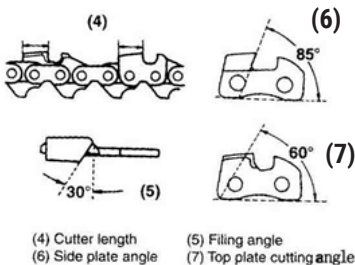

9.9.6 GEAR CASE

The reduction gears are lubricated by multipurpose, lithium-based grease in the gear case.

Supply new grease every 25 hours of use, or more often based on the job condition.

When adding lubricant, use a grease gun to insert lubricant into the three grease nipples located on the gear case.

NOTE

When removing and installing the cutting holder (a), be extra cautious to not allow any dirt and dust to enter the gear case.

10. STORAGE

Aged fuel is one of major causes of engine starting failure.

Before storing the unit, empty the fuel tank and run the engine until it uses all the fuel left in the fuel line and or the carburettor.

Store the unit indoor taking necessary measures for rust prevention.

11. TROUBLESHOOTING GUIDE

CASE 1. STARTING FAILURE

CHECK	PROBABLE CAUSES	ACTION
Fuel Tank	Incorrect Fuel	Drain it and use correct fuel
Fuel Filter	Fuel Filter is clogged	Clean
Carburettor adjustment screw	Out of normal range	Adjust to normal range
Sparking (no spark)	Spark plug is fouled/wet Plug gap is incorrect	Clean /dry Correct (GAP:0.6-0.7)
Spark plug	Disconnected	Retighten

CASE 2. ENGINE STARTS BUT DOES NOT KEEP RUNNING/HARD RE-STARTING

CHECK	PROBABLE CAUSES	ACTION
Fuel tank	Incorrect fuel or staled fuel	Drain it and use correct fuel
Carburettor adjustment screw	Out of normal range	Adjust to normal range
Muffler, cylinder (exhaust port)	Carbon is built-up	Wipe away
Air cleaner	Clogged with dust	Wash
Cylinder fin, fan cover	Clogged with dust	Clean

12. WARRANTY

Subject to the following conditions, this unit is covered by a comprehensive two-year warranty.

The unit is designed for domestic purposes only, issues and faults due to commercial use may not be covered by warranty. The warranty covers all manufacturing faults but excludes normal wear and tear, misuse, neglect, accidental damage or defects arising from failure to comply with instructions as outlined in this owners manual. Only genuine spare parts can be used for repairs and this must be carried out by an authorised LawnMaster Services Dealer to maintain warranty.

Warranty does not cover the cost of transportation of any part(s) but does cover the labour/parts cost incurred in repairing or replacing any defective part(s) consequential or special damages and / or expenses resulting from any defect.

If the unit requires further repairs or services please visit www.steelfort.co.nz to find your local service dealer.

For all other enquiries contact **Steelfort Customer Services +64 6 350 1350**

LawnMaster

Steelfort

500 Rangitikei Street
Private Bag 11045
Palmerston North, 4442, New Zealand
06 350 1350 | steelfort.co.nz

Steelfort Auckland

880 Great South Road, Penrose
Auckland, 1061, New Zealand
09 573 1324 | outlet@steelfort.co.nz



SCAN TO VIEW THE
LAWNMASTER RANGE